



Sanitární kabinky a příčky, lamino tl. 18 mm, Al profil, do suchých prostor
Sanitary cubicles and partitions, 18 mm thick laminate, aluminium profile, for dry indoor areas

Variety otevírání dveří / Door opening options: **I.** → otevírání ven / outward opening → strana 1-24 / pages 1-24
II. → otevírání dovnitř / inward opening → strana 25-48 / pages 25-48

CS Montážní návod	RU Инструкция по монтажу	RO Instrucțiuni de montaj	NL Montage instructie
SK Montážny návod	DE Montageanleitung	ES Manual de instrucciones	LT Montavimo instrukcija
EN Mounting instructions	PL Instrukcja montażu	FR Notice de montage	HU Szerelési útmutató

I. → otevírání ven / outward opening → strana 1-24 / pages 1-24

CS Specifikace dodávky	RU Спецификация поставки	RO Componente livrate	NL Leveringsomvang
SK Špecifikácia dodávky	DE Lieferumfang	ES Especificación de suministro	LT Tiekimo specifikacija
EN Supplied equipment	PL Specyfikacja dostawy	FR Equipements fournies	HU Tartozékok

SLKA 01W18A - obj. č. (Code Nr.) - 40012

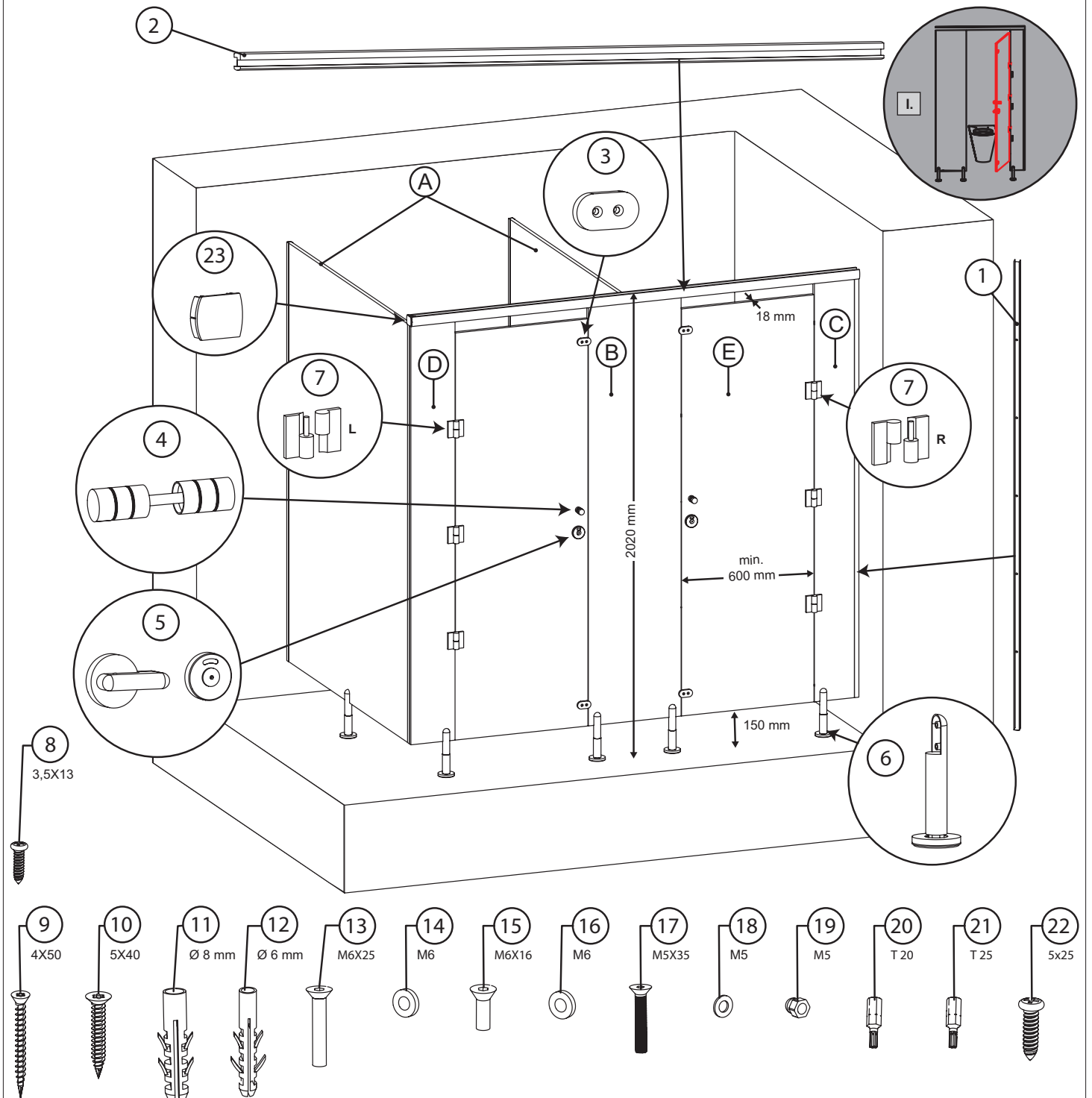

(CS) Doporučené nástroje
(SK) Odporúčané nástroje
(EN) Required tools

(RU) Рекомендуемые инструменты
(DE) Empfohlene Werkzeuge
(PL) Zalecane narzędzia

(RO) Instrumente recomandate
(ES) Herramientas recomendadas
(FR) Outils recommandés

(NL) Aanbevolen tools
(LT) Rekomenduojami įrankiai
(HU) Ajánlott eszközök

 2 osoby
2 person

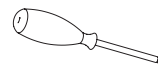
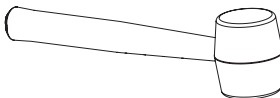
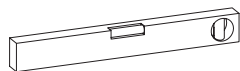
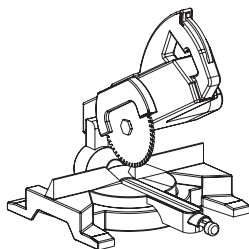
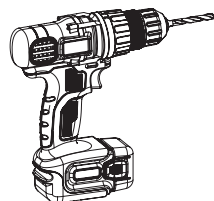

(CS) Instalace
(SK) Inštalácia
(EN) Installation

(RU) Схема включения и монтажа
(DE) Installation
(PL) Instalacja

(RO) Instalare
(ES) Instalación
(FR) Installation

(NL) Installatie
(LT) Montavimo ir įjungimo schema
(HU) Beüzemelés

Varianta otevírání / Opening option: **I.** → ven / out

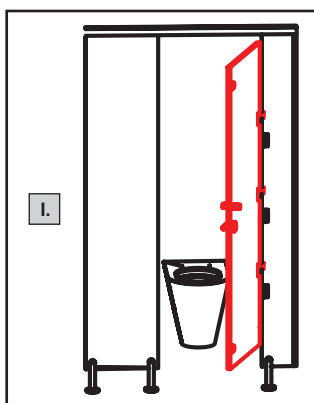

UPOZORNĚNÍ

Prvním krokem je rozměření prostoru montáže, zohlednění nerovností stávajících konstrukcí, prověření materiálu nosných stěn, do kterých bude konstrukce kotvena, popřípadě materiálu obkladu stěn a zvolení tomu odpovídajícího náčiní. Nutno prověřit místa rozvodu médií v navazujících konstrukcích – voda, elektroinstalace a podobně. Pokud je v místnosti podlahové vytápění, rektifikační nohy k podkladu přilepíme vhodným lepidlem.

WARNING

The first step is to measure the installation area, take into account the imperfections of the existing structures, check the material of the supporting walls into which the framework will be anchored, or the material of the wall tiling, and choose the appropriate tools. It is necessary to check the locations of the supply of mediums in the surrounding structures - water, wiring, etc. If there is underfloor heating in the room, glue the rectification legs to the floor with a suitable adhesive.



CS – Před instalací je nezbytné důkladně se seznámit s příloženými Bezpečnostními pokyny.

EN – Before installation, it is essential to thoroughly familiarize yourself with the attached Safety Instructions.

SK – Pred inštaláciou je nevyhnutné dôkladne sa oboznámiť s príloženými Bezpečnostnými pokynmi.

RU – Перед установкой необходимо внимательно ознакомиться с приложенными инструкциями по безопасности.

DE – Vor der Installation ist es erforderlich, sich gründlich mit den beigefügten Sicherheitsanweisungen vertraut zu machen.

PL – Przed instalacją konieczne jest dokładnie zapoznanie się z dołączonymi instrukcjami bezpieczeństwa.

RO – Înainte de instalare, este necesar să vă familiarizați temeinic cu instrucțiunile de siguranță atașate.

ES – Antes de la instalación, es esencial familiarizarse a fondo con las instrucciones de seguridad adjuntas.

FR – Avant l'installation, il est indispensable de bien prendre connaissance des instructions de sécurité jointes.

NL – Voor de installatie is het noodzakelijk om de bijgevoegde veiligheidsinstructies zorgvuldig door te lezen.

LT – Prieš montavimą būtina atidžiai susipažinti su pridėtomis saugos instrukcijomis.

HU – A telepítés előtt elengedhetetlen, hogy alaposan megismerkedjen a mellékelt biztonsági utasításokkal.

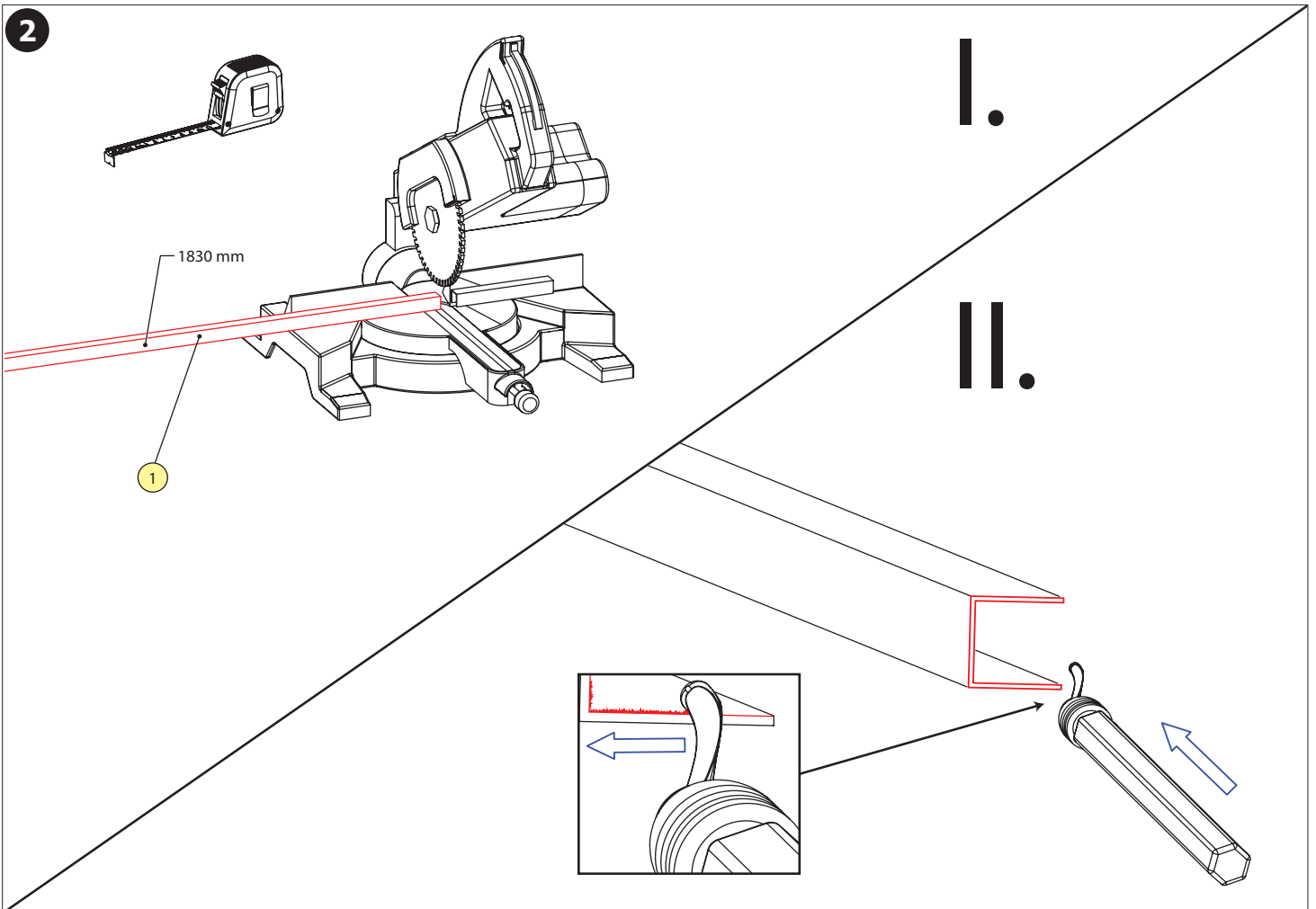
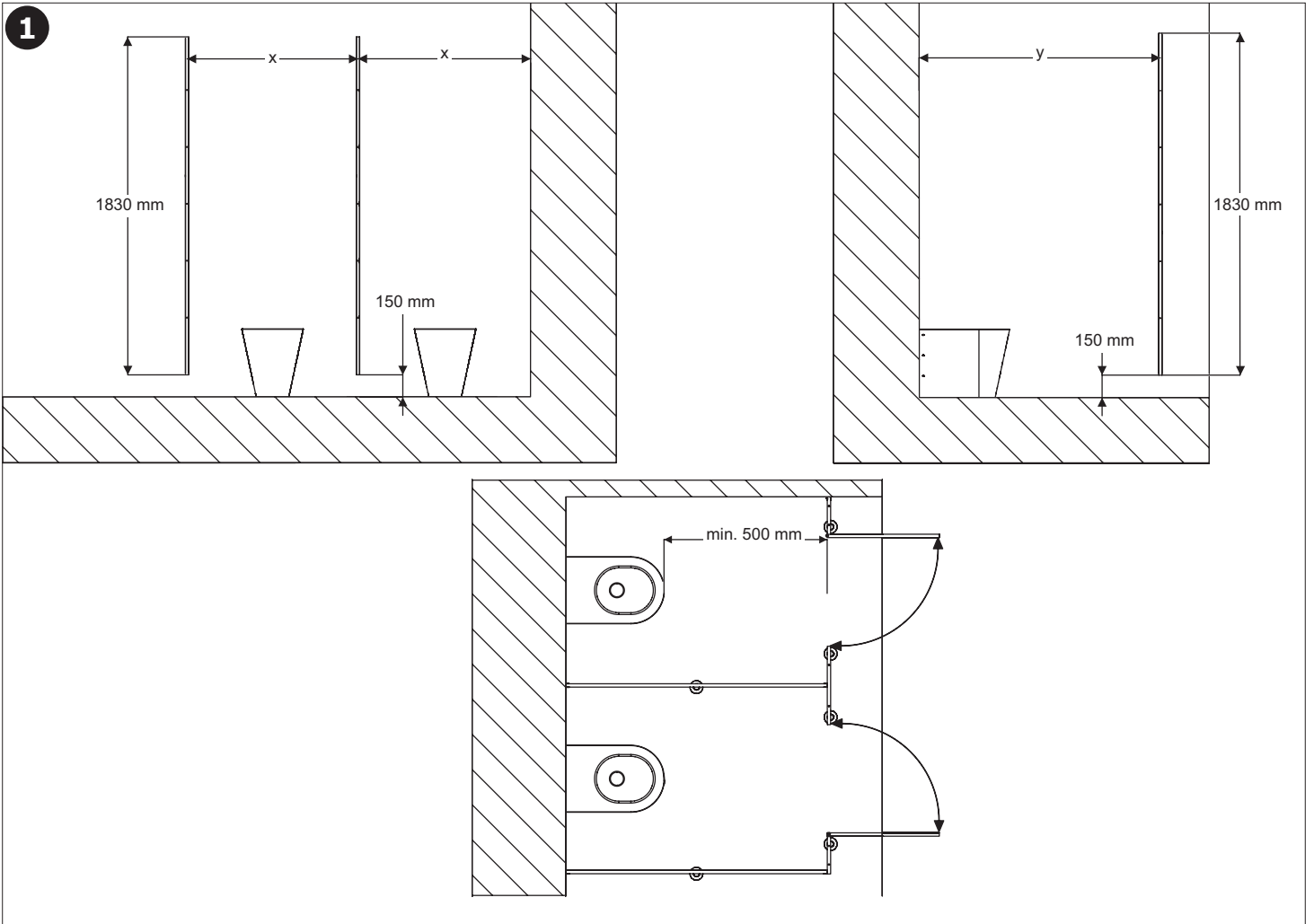

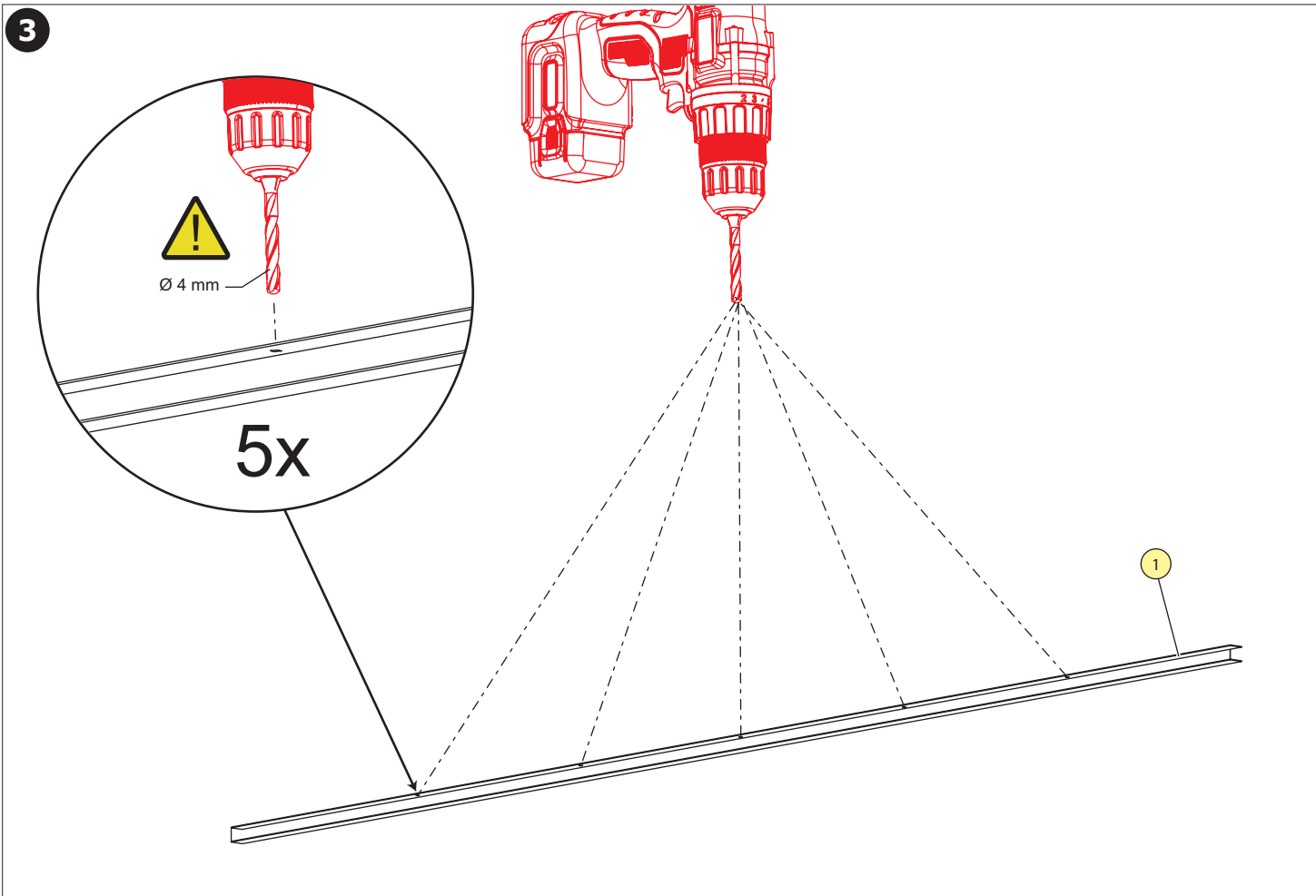

Rozdělení profilu / Profile segmentation: **A** → stěnový profil / wall profile
B → profil středové desky / central plate profile

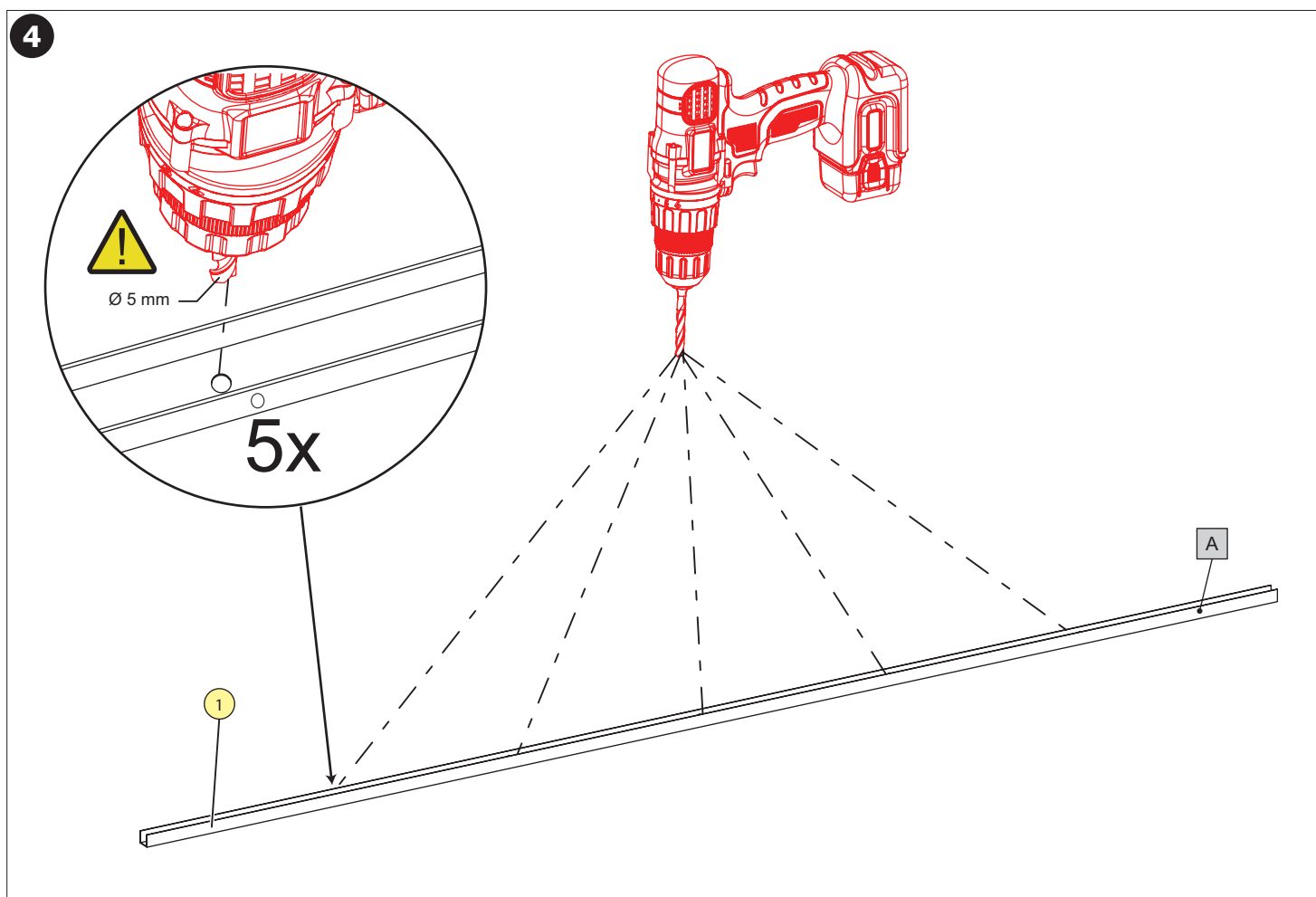

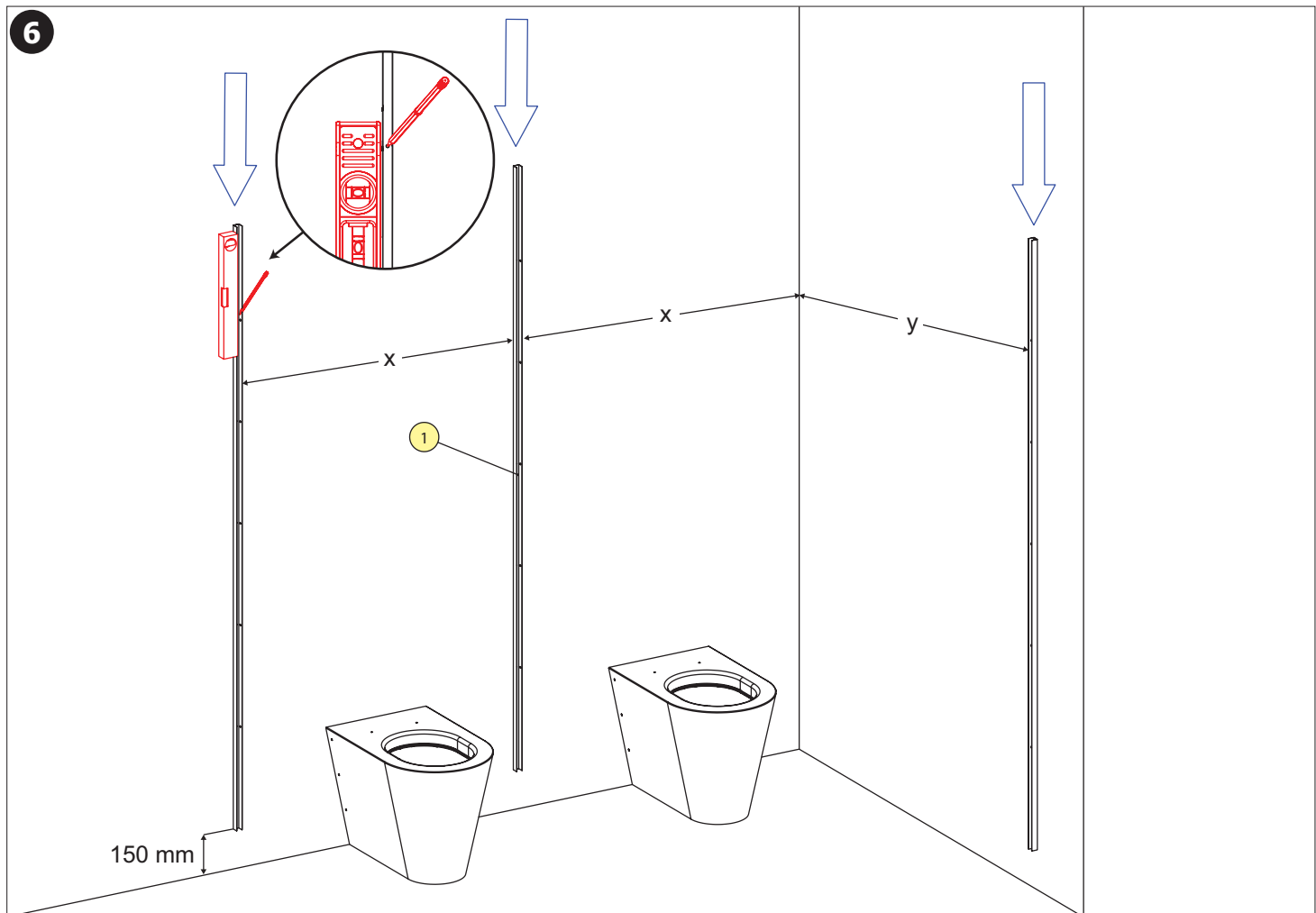
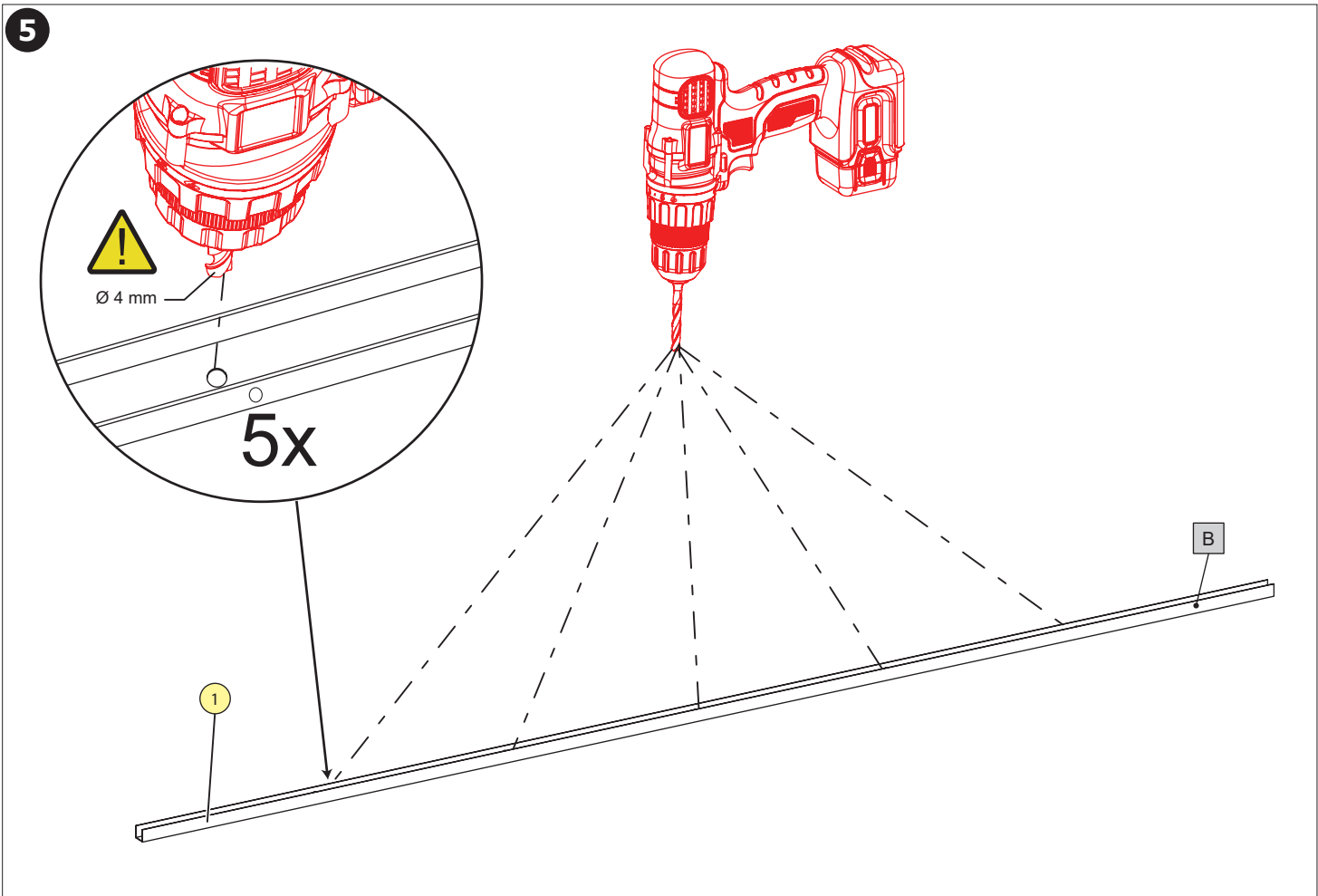

7

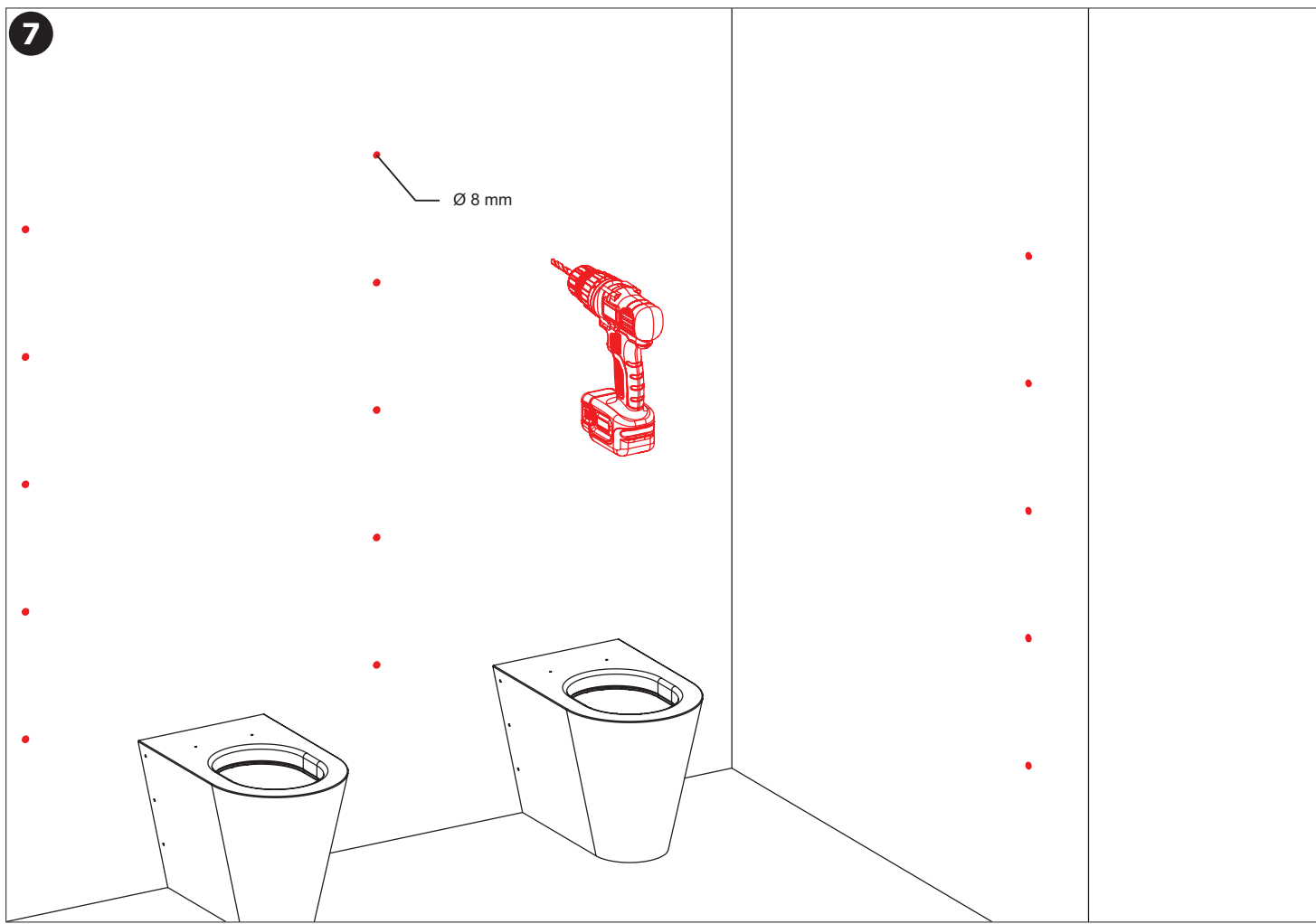

8

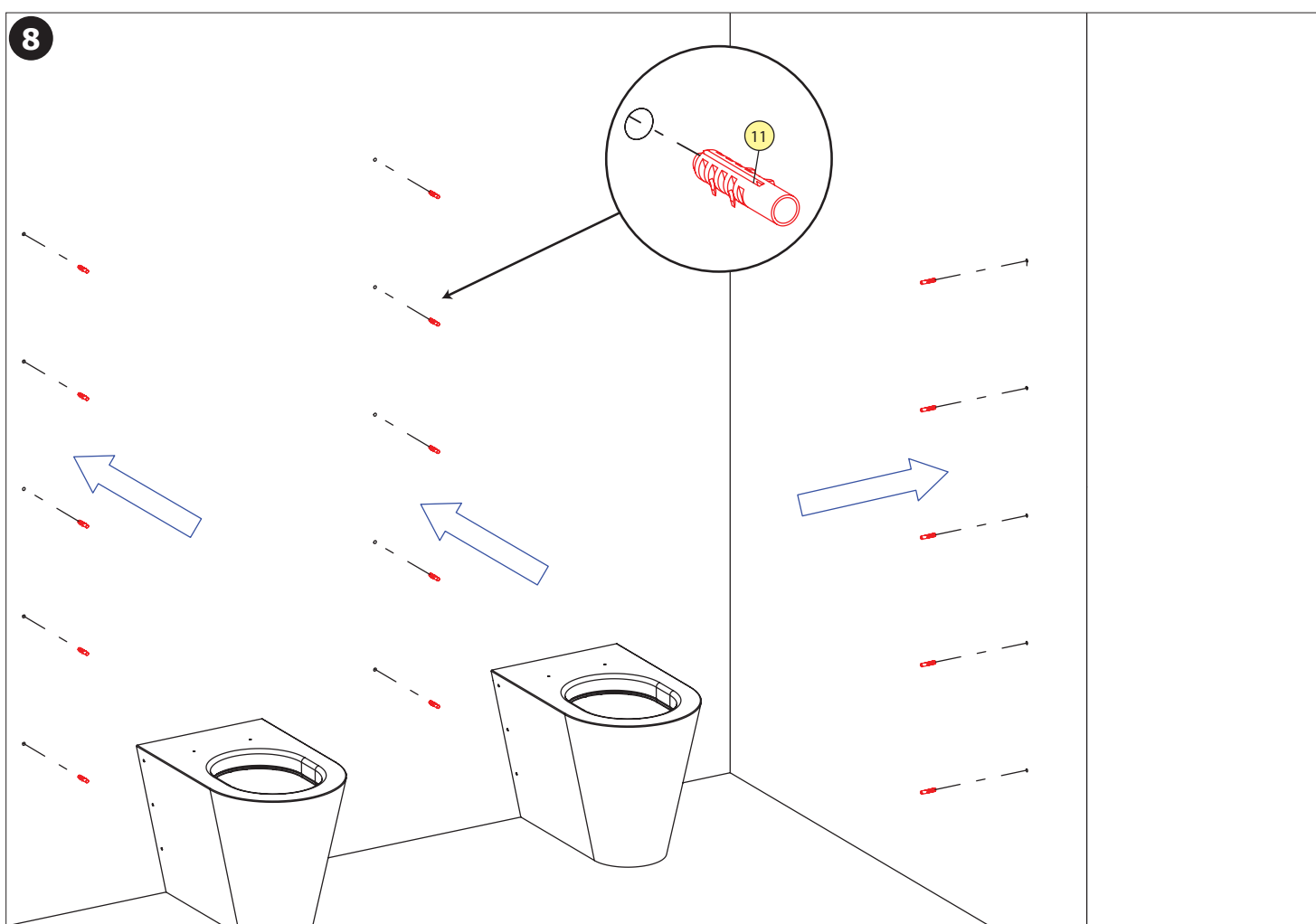

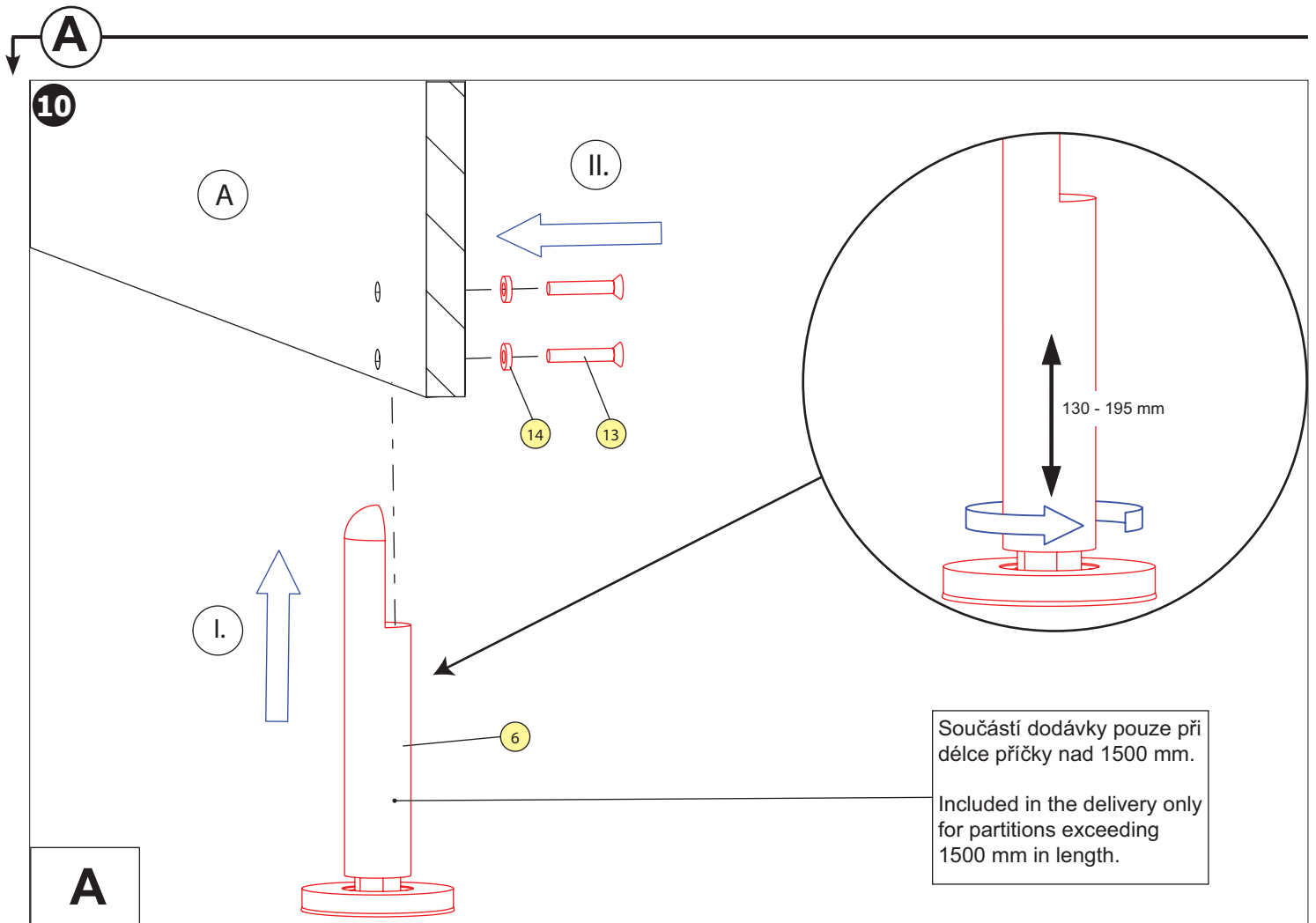
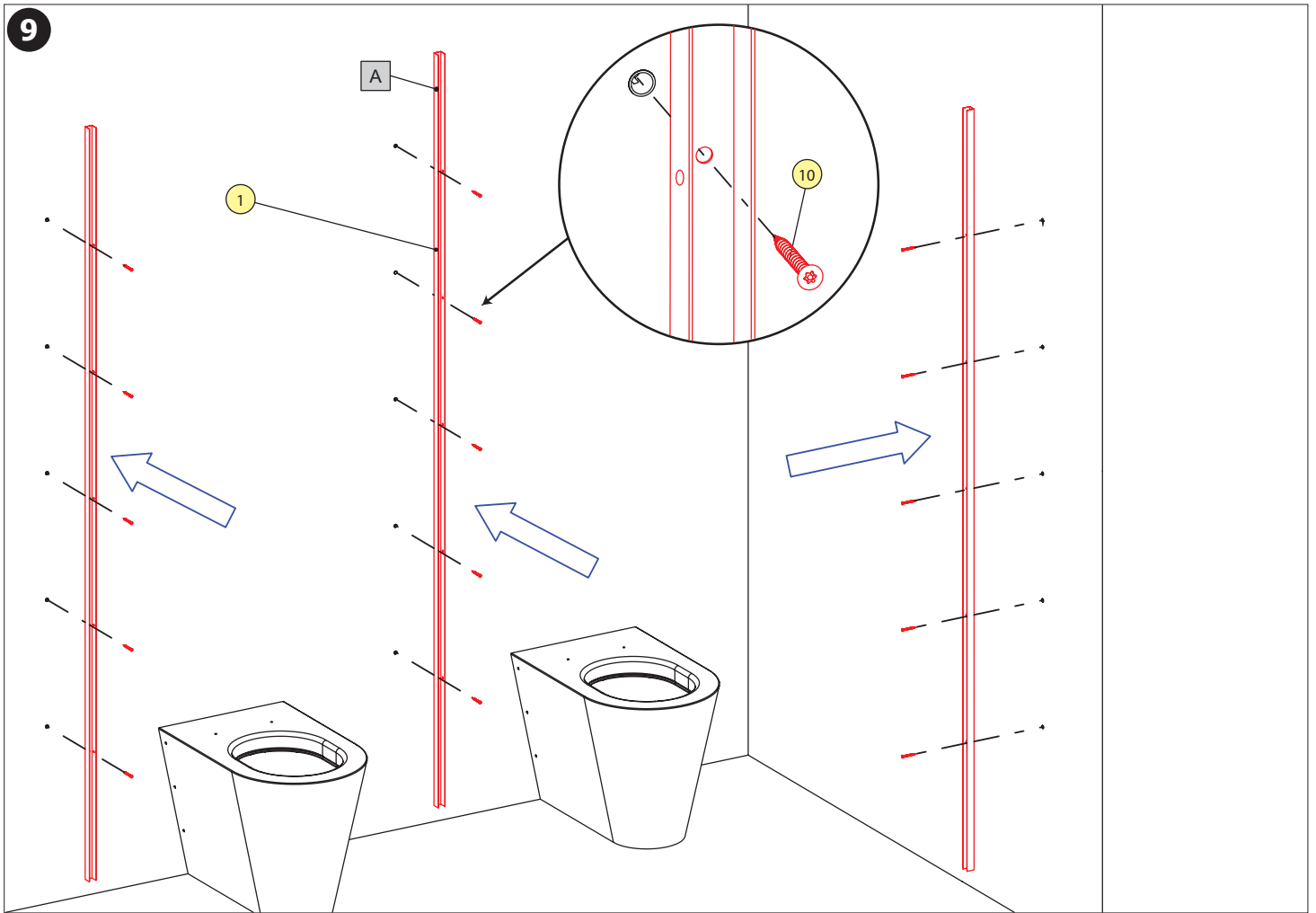

11

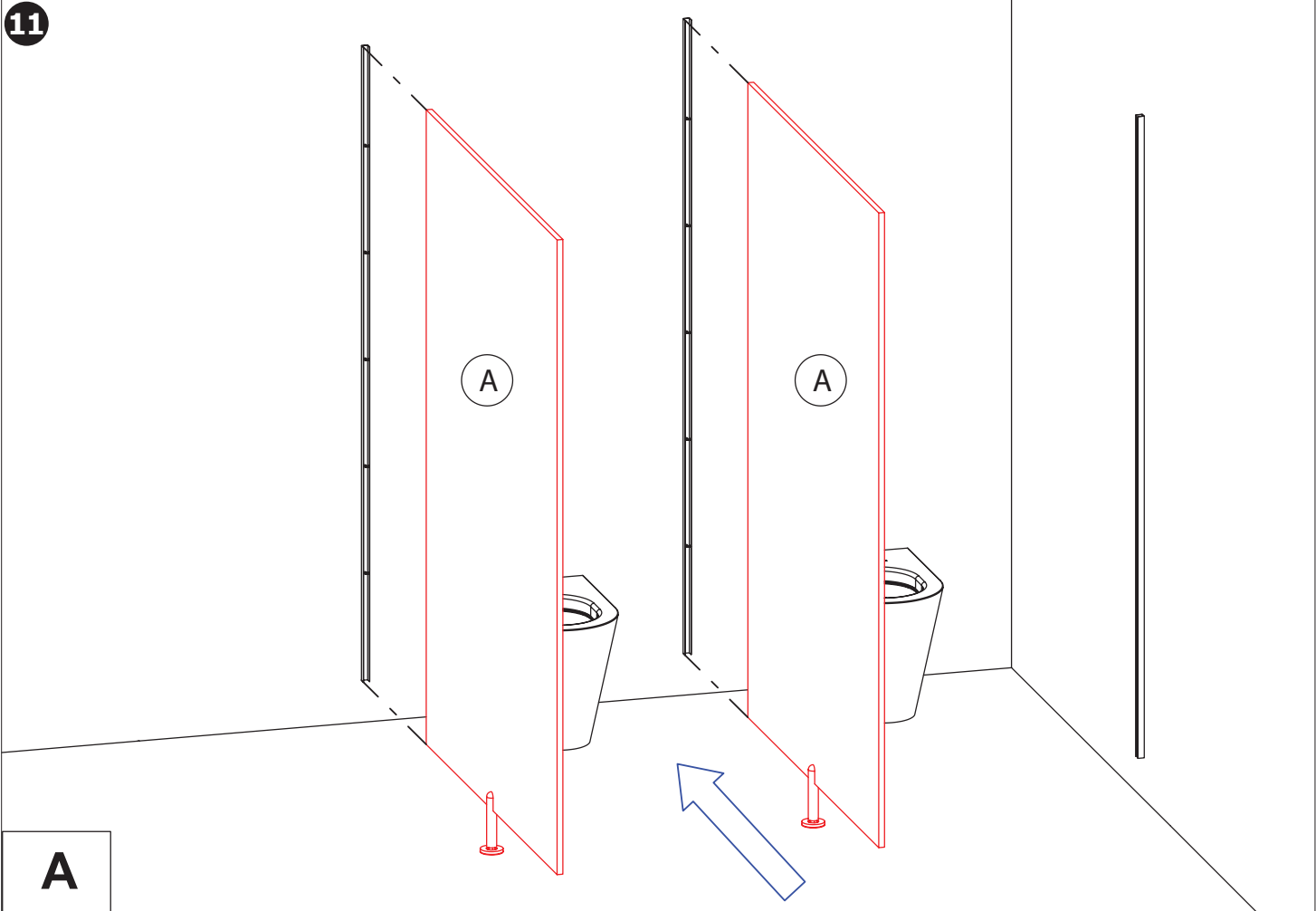

A

12



A

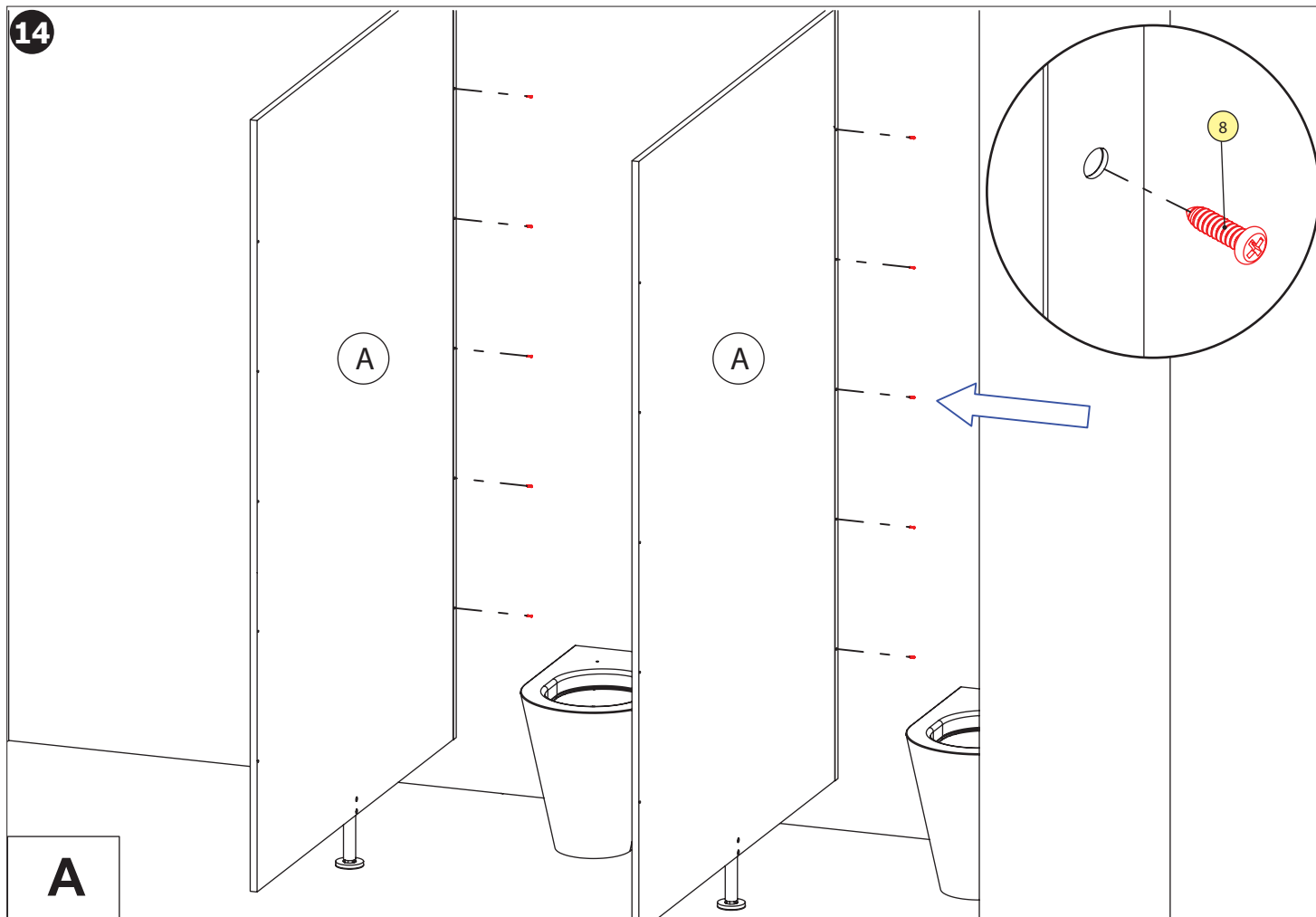
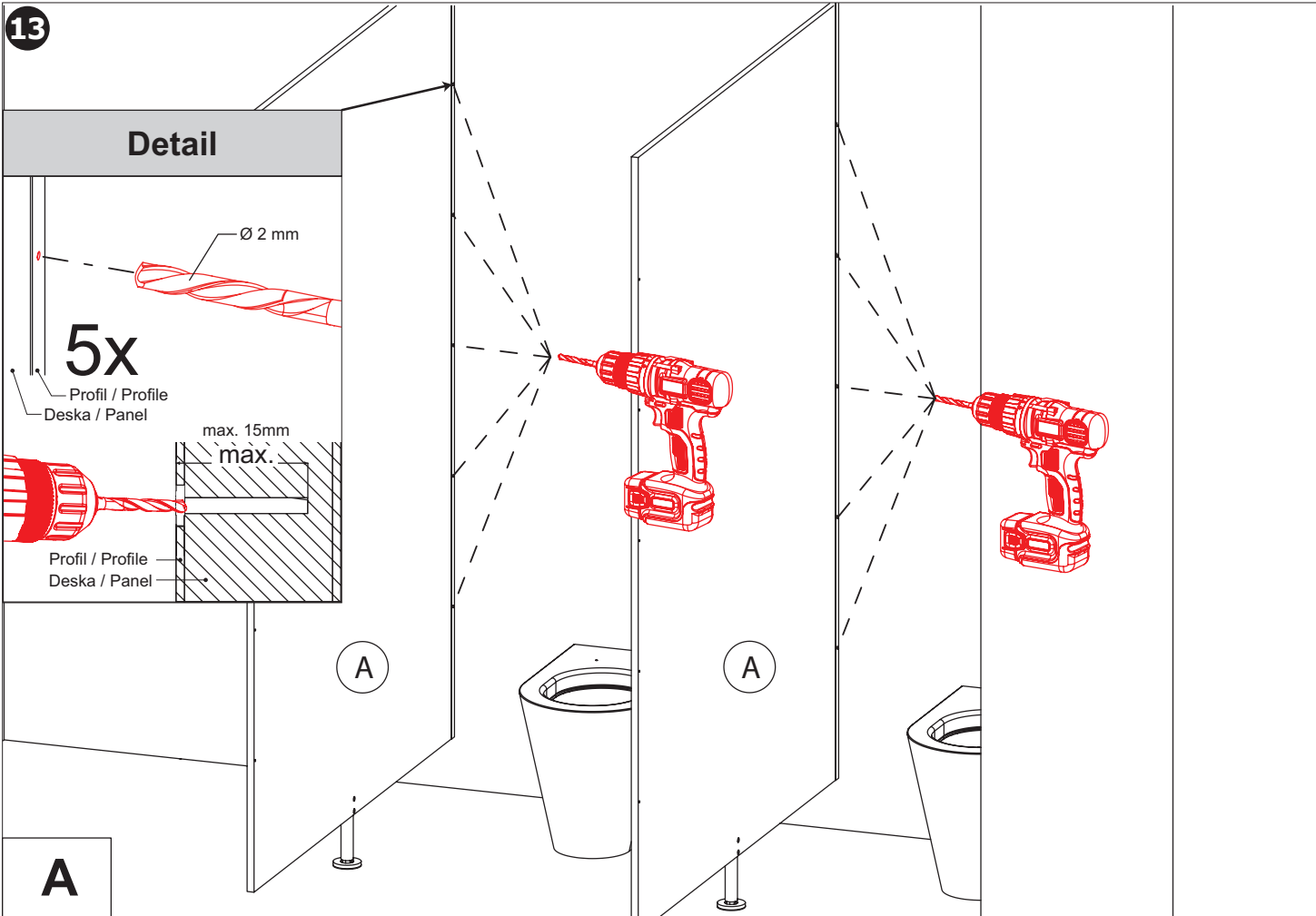

B

15

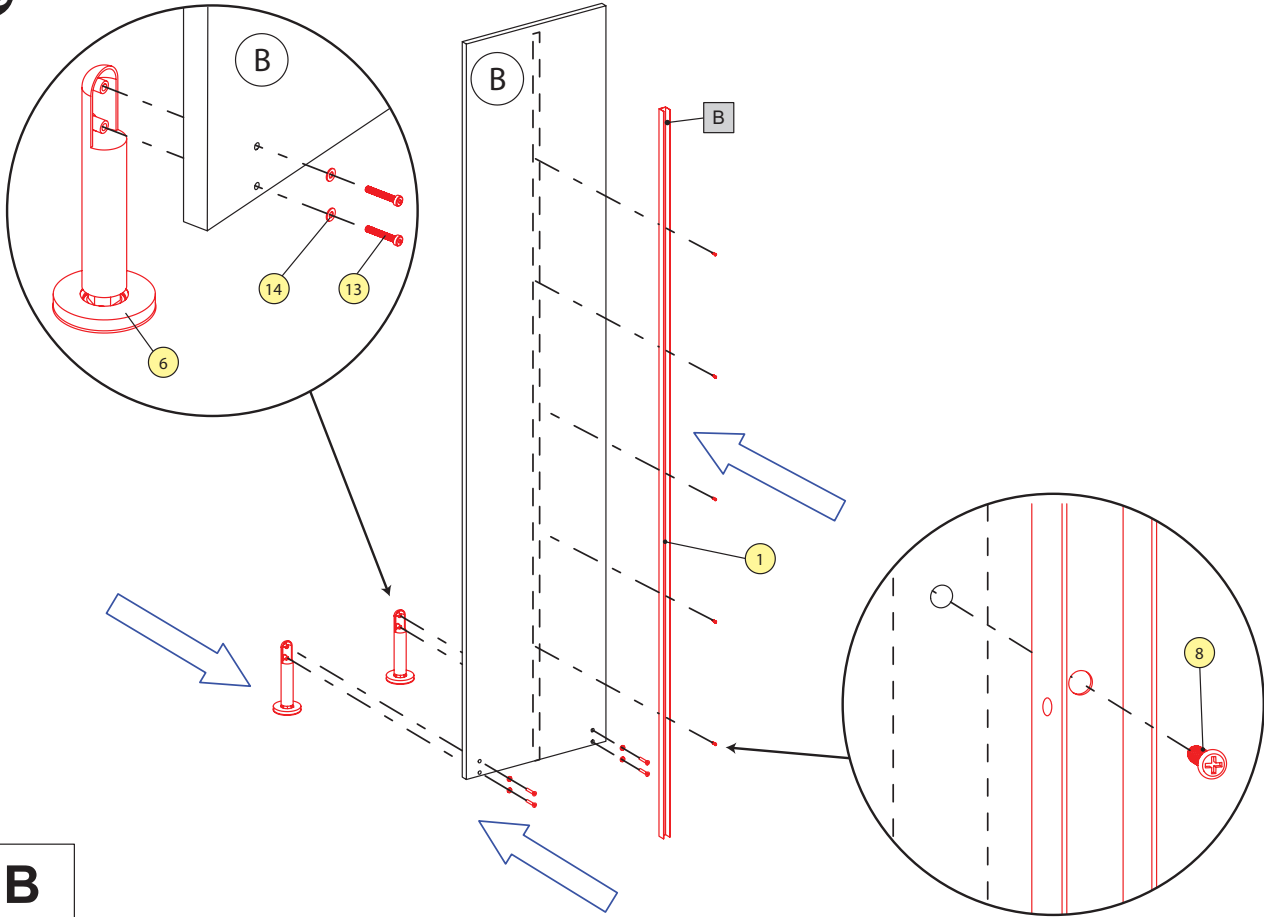

B

Detail

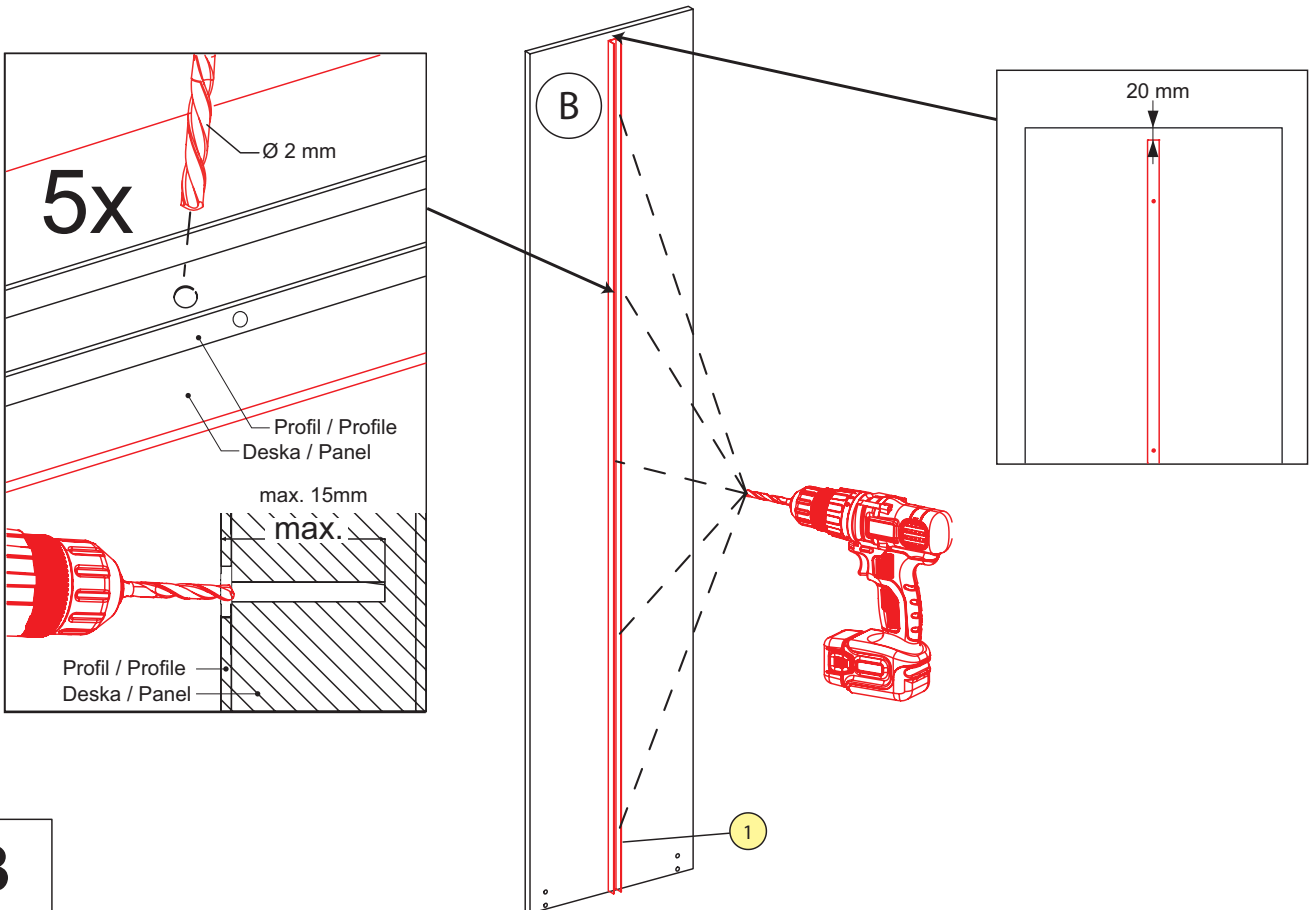

B

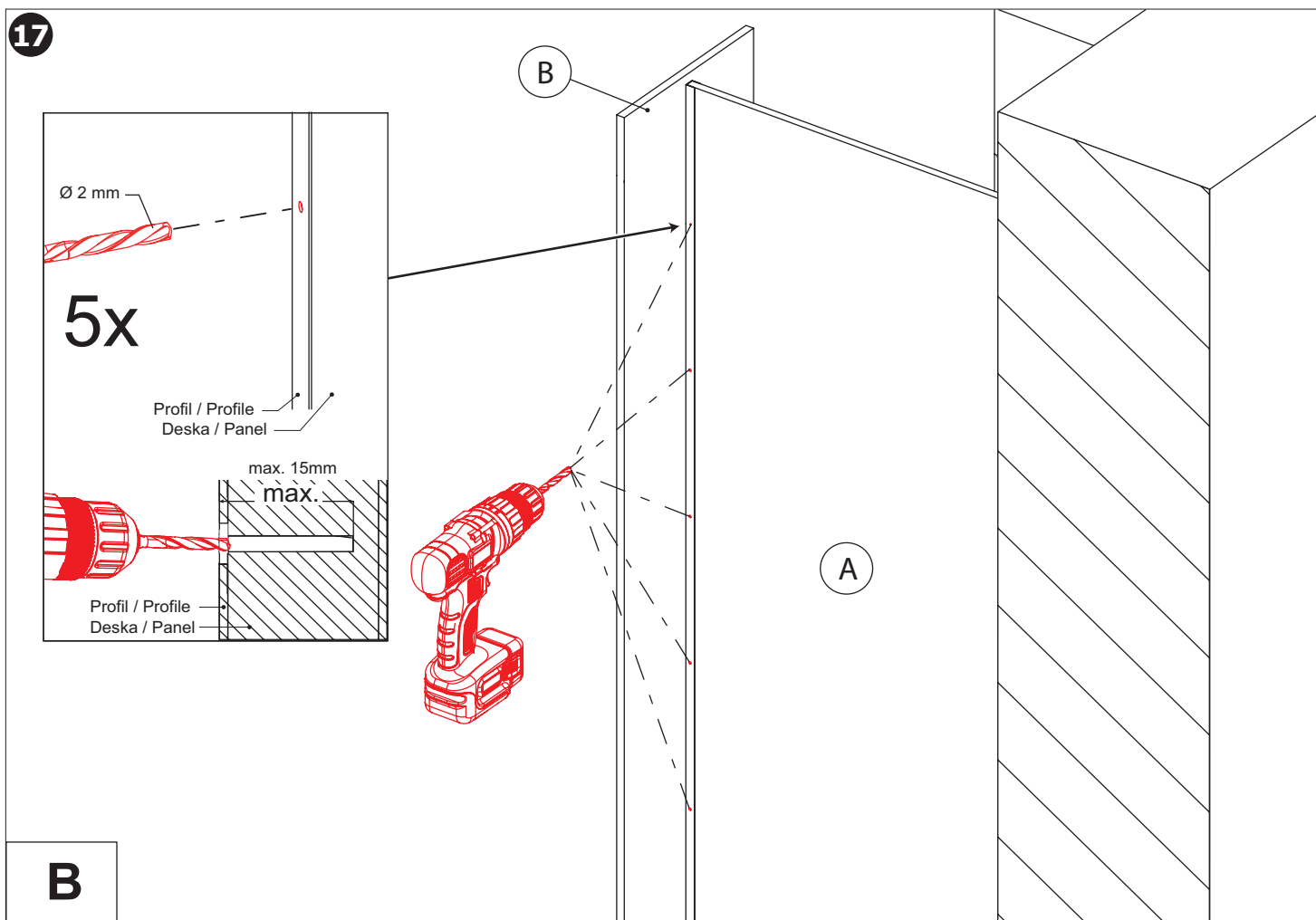
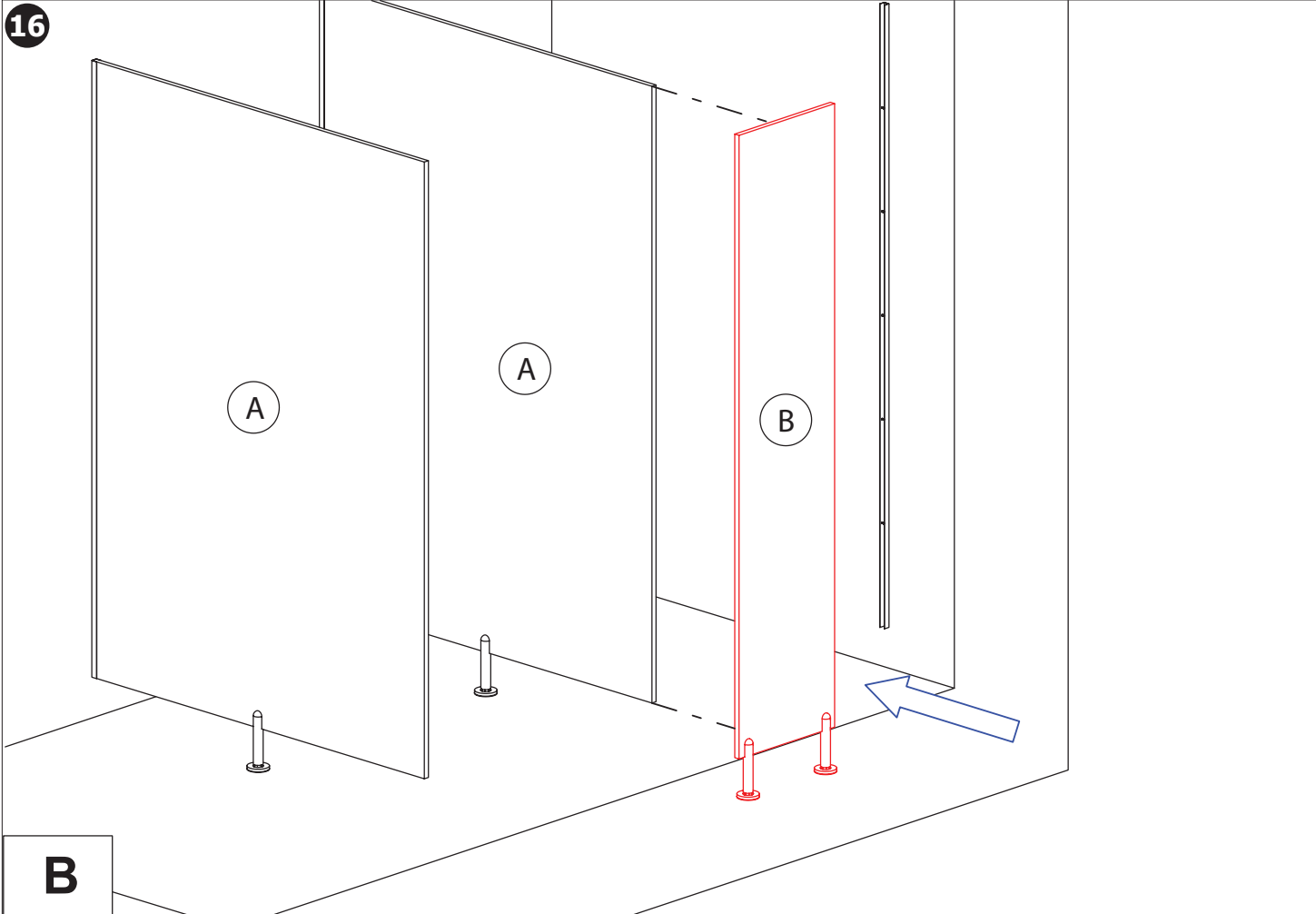

18

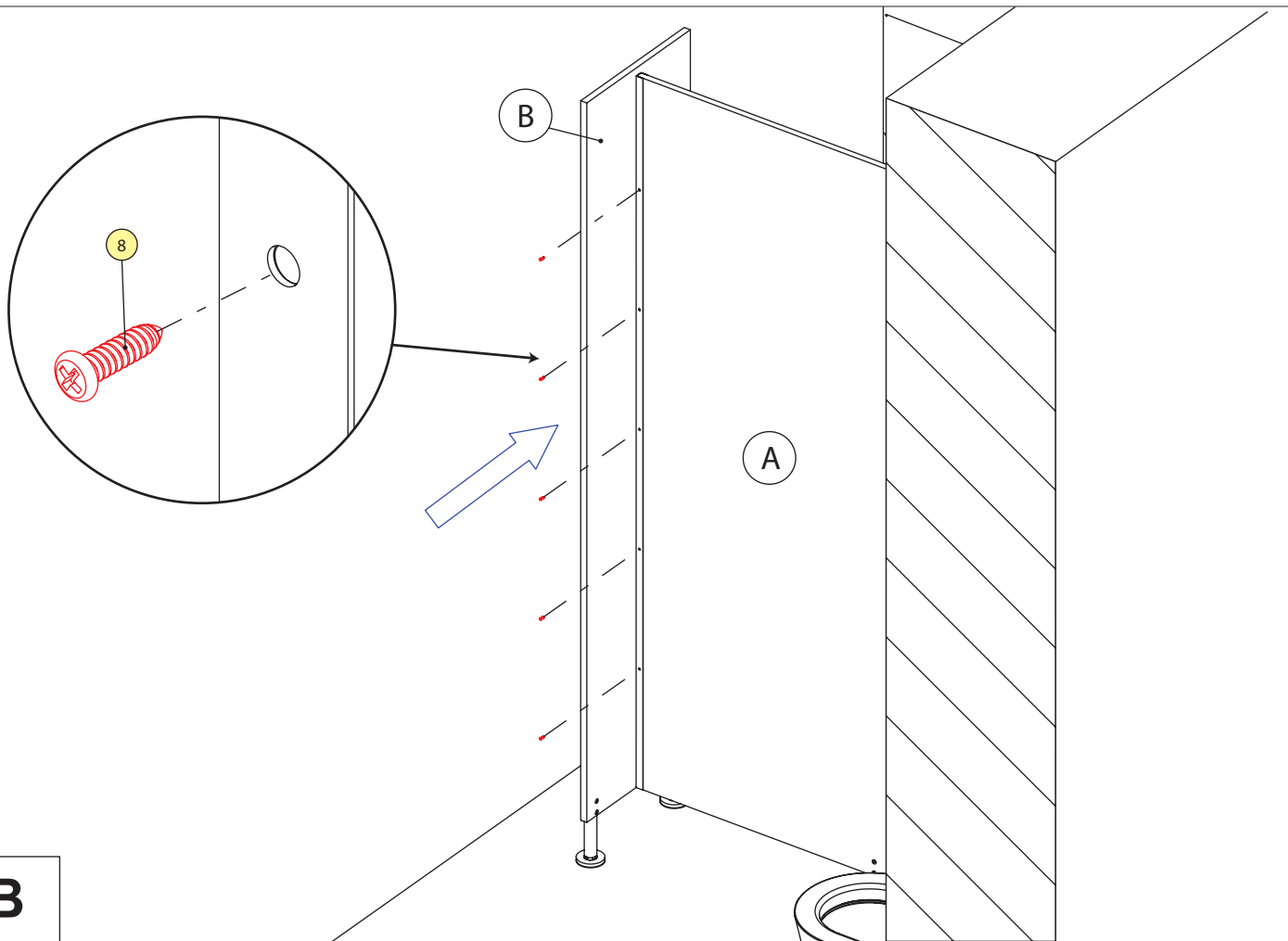

B

C

19

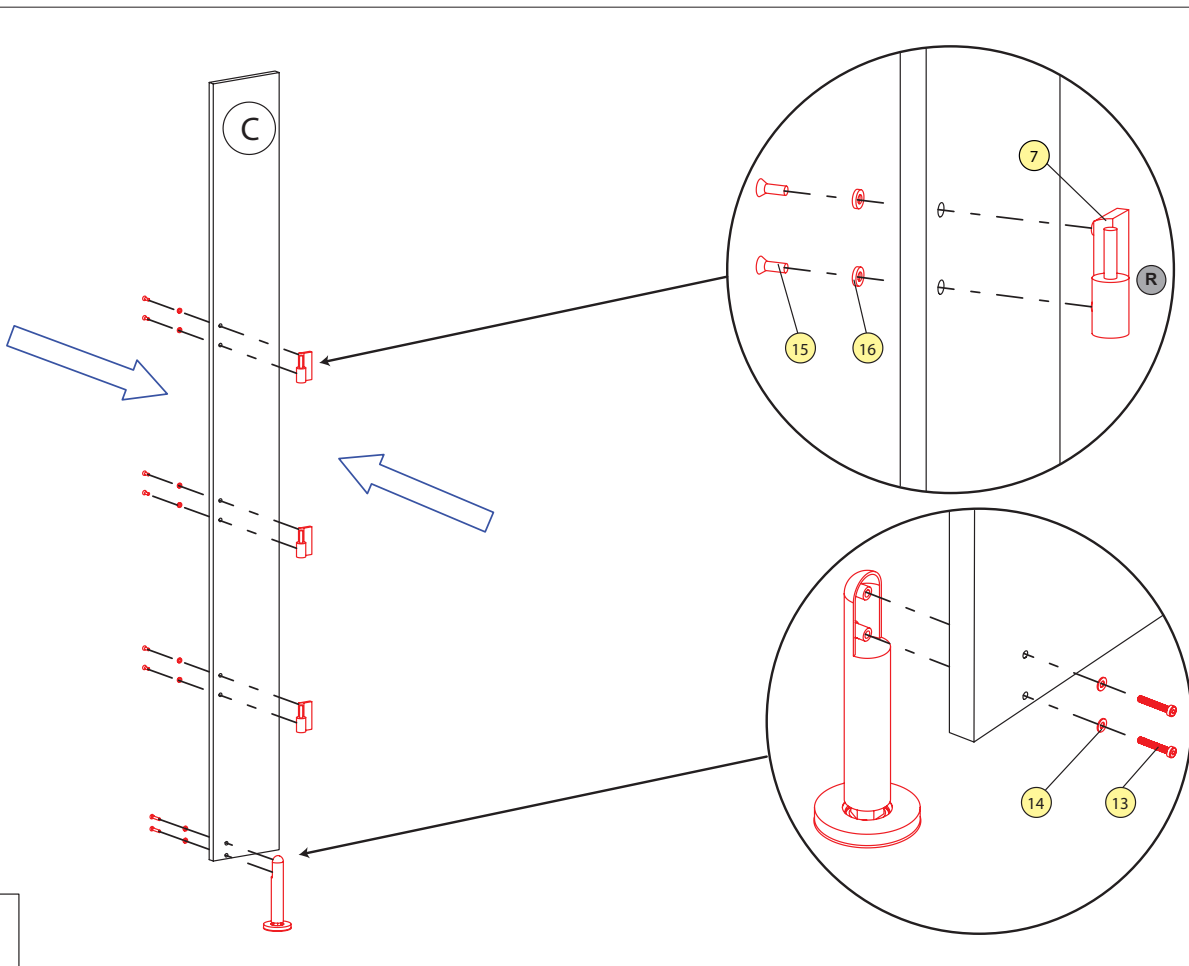

C

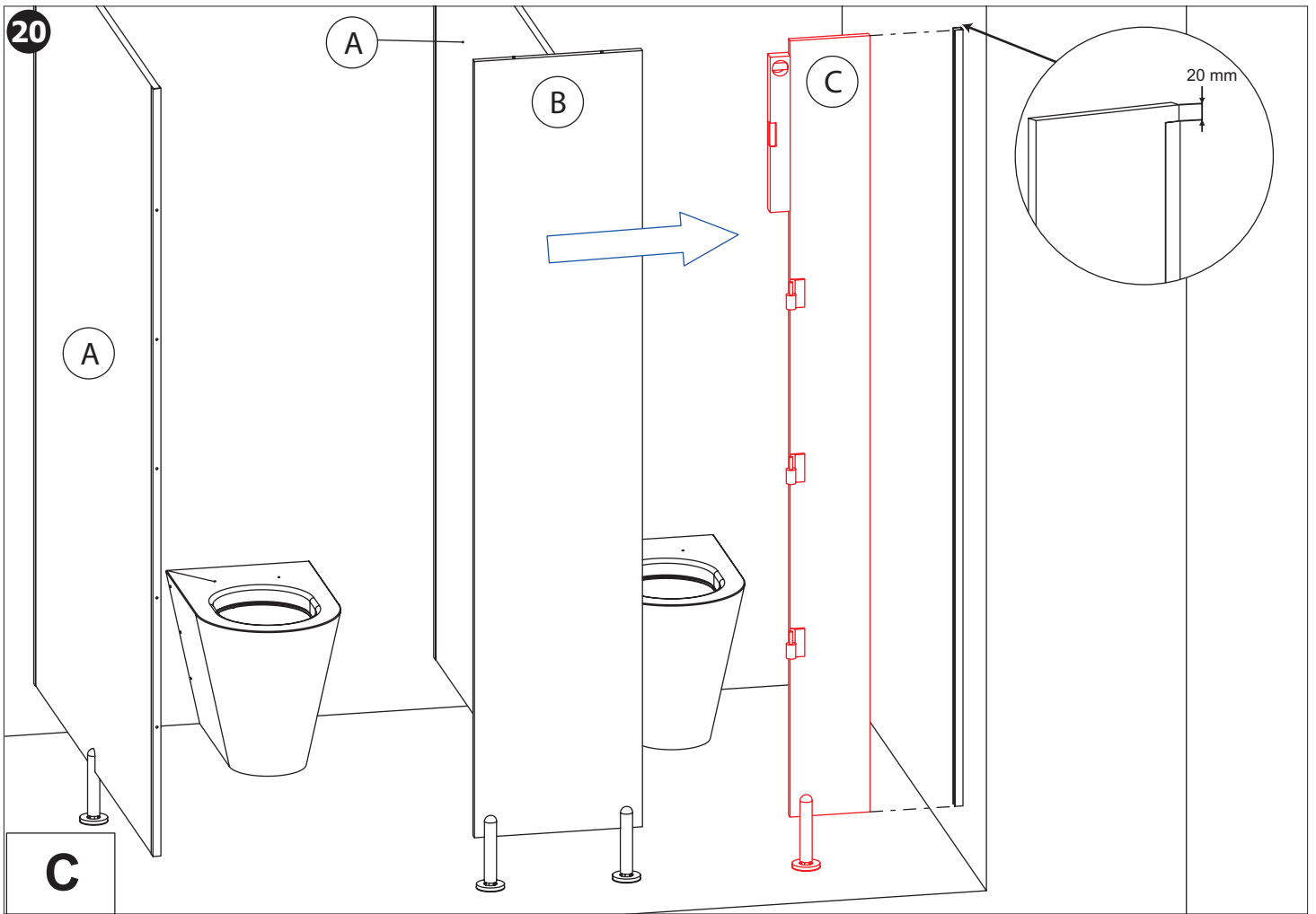

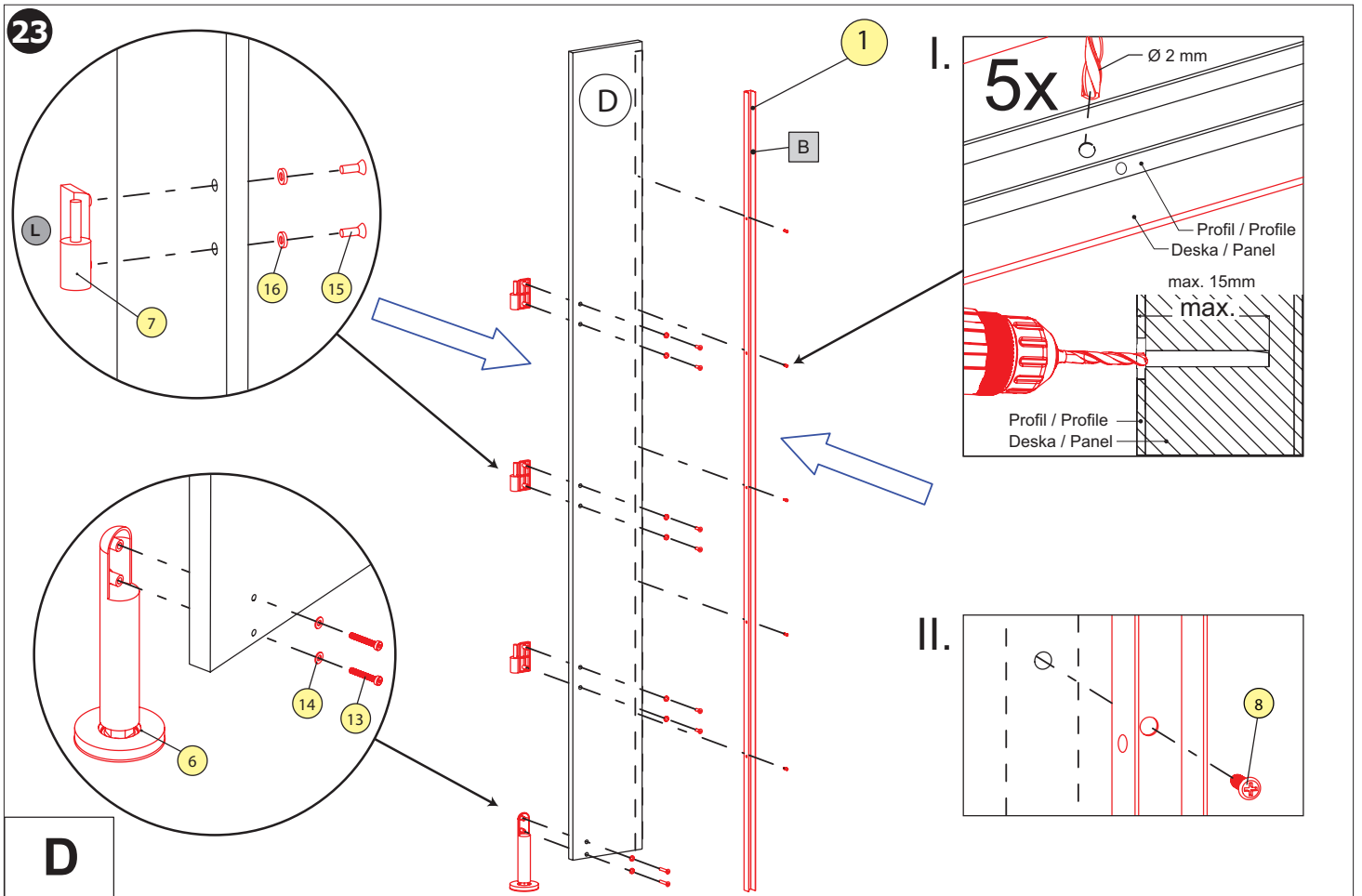
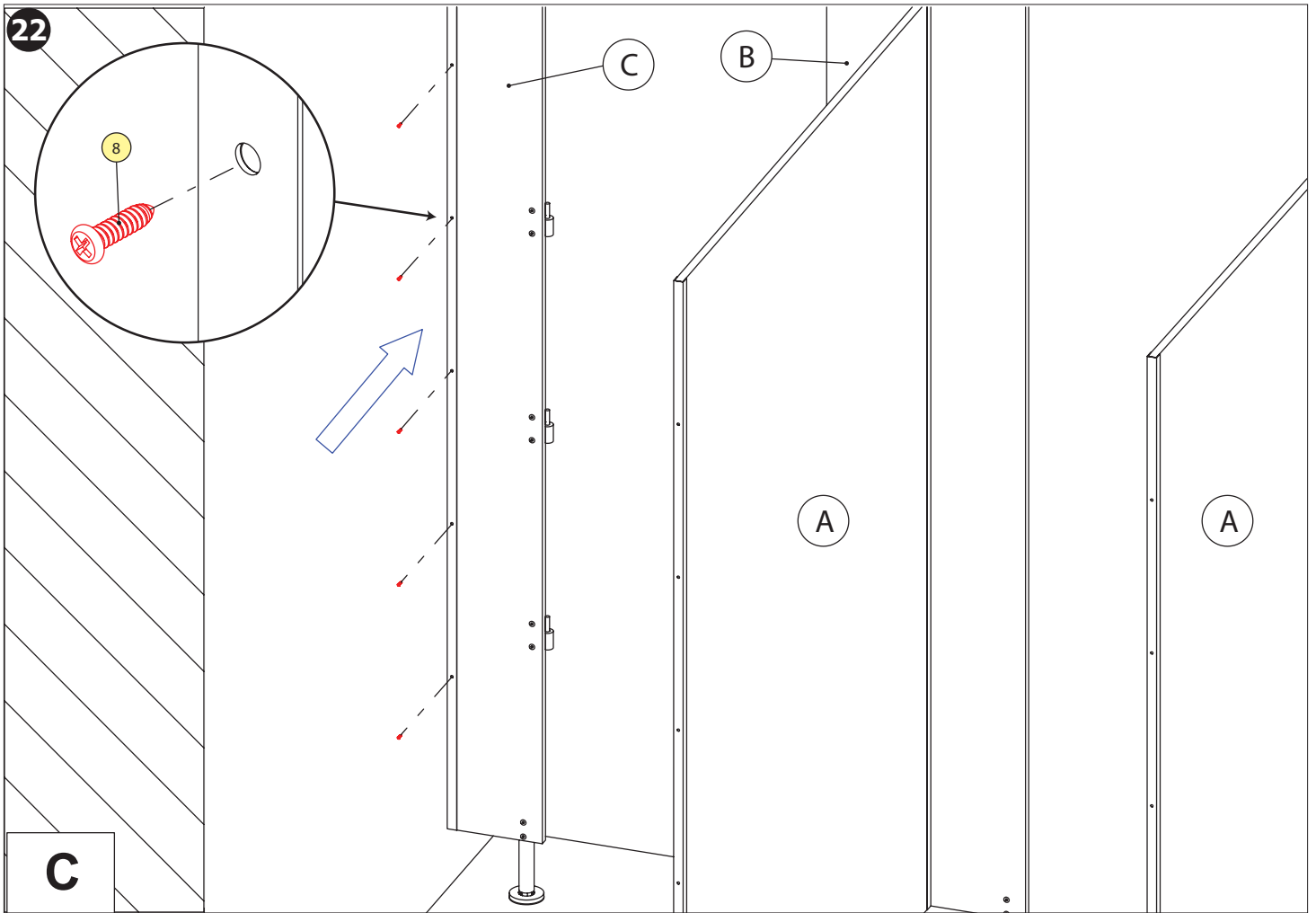

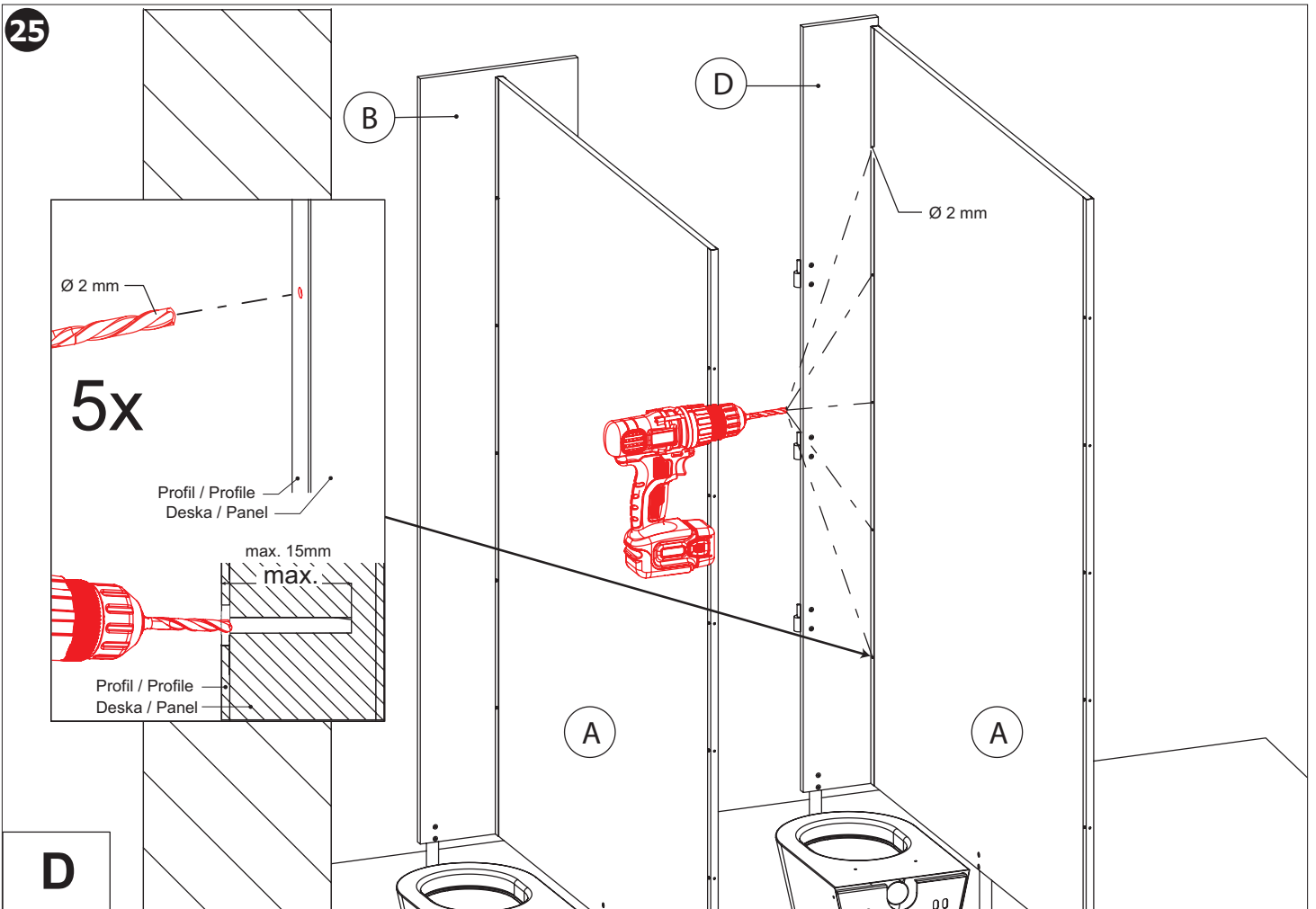
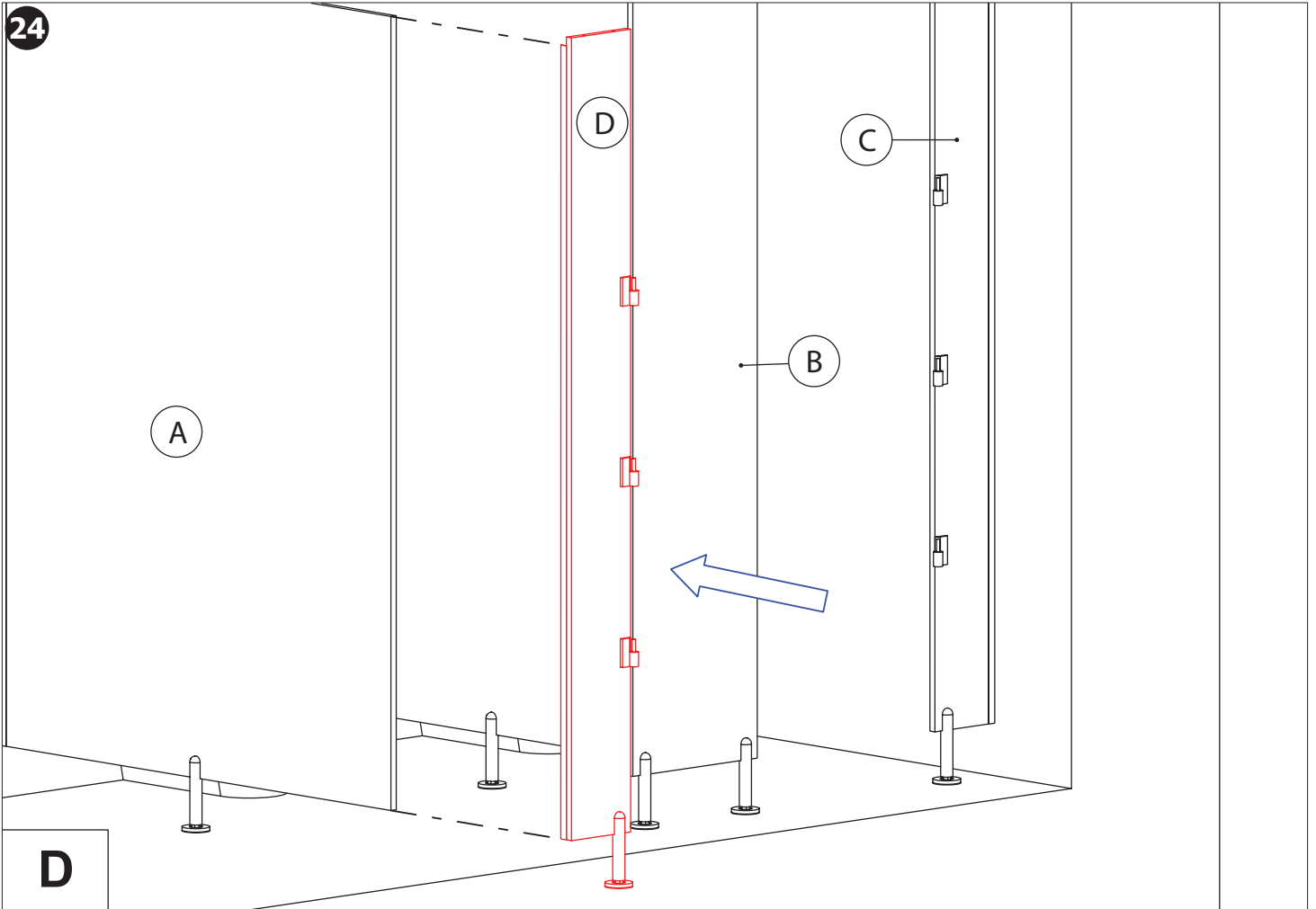

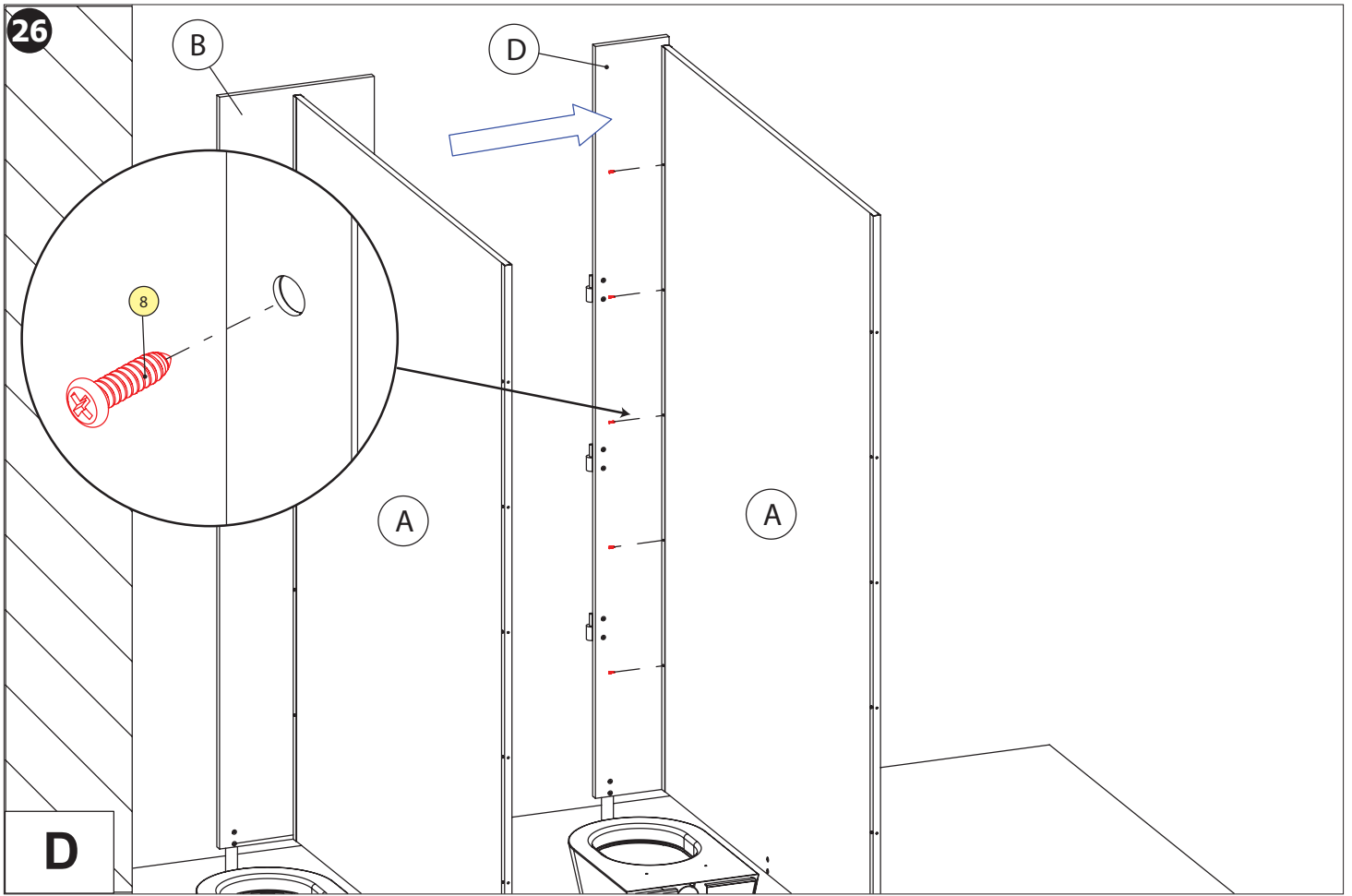

E

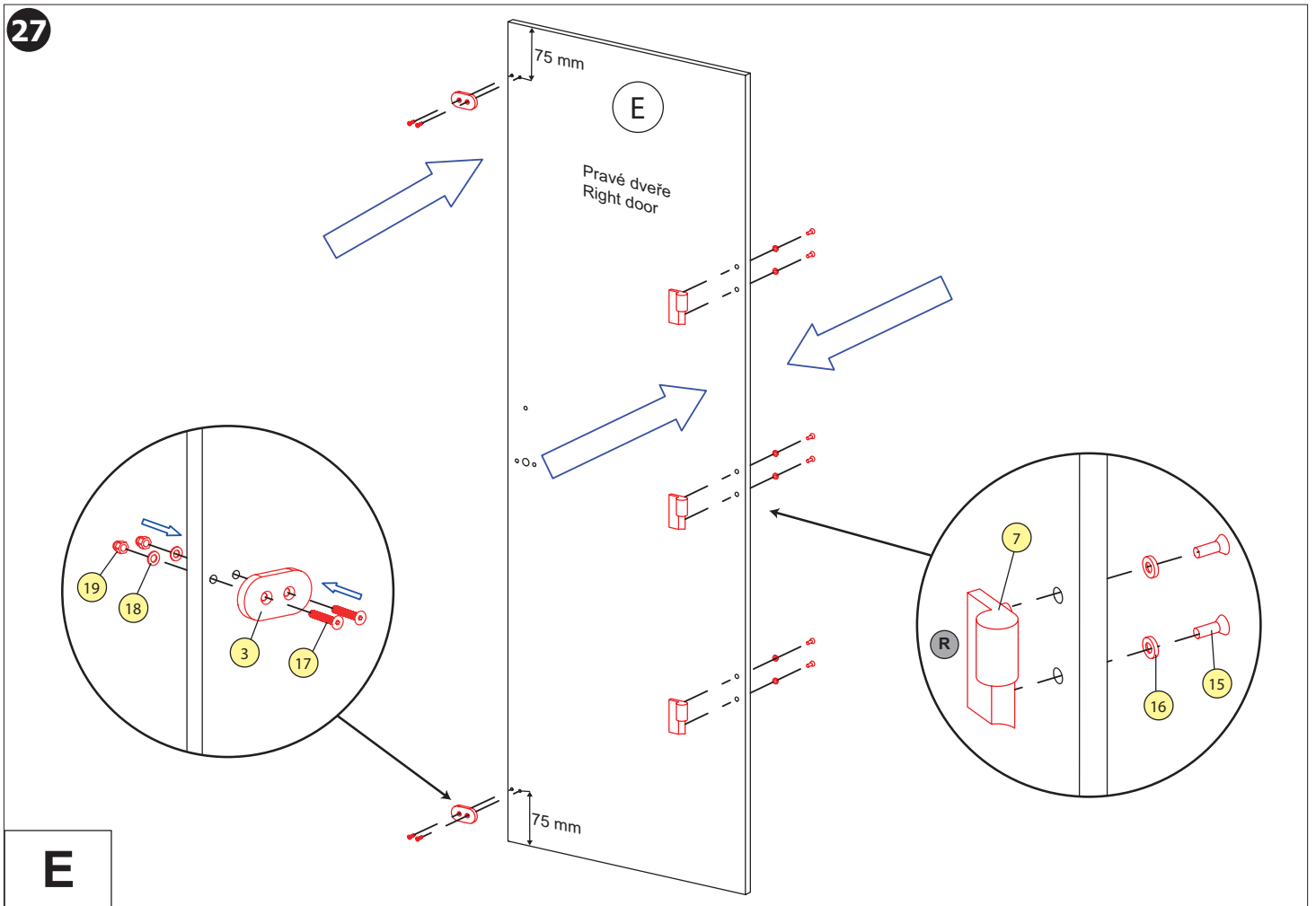

28

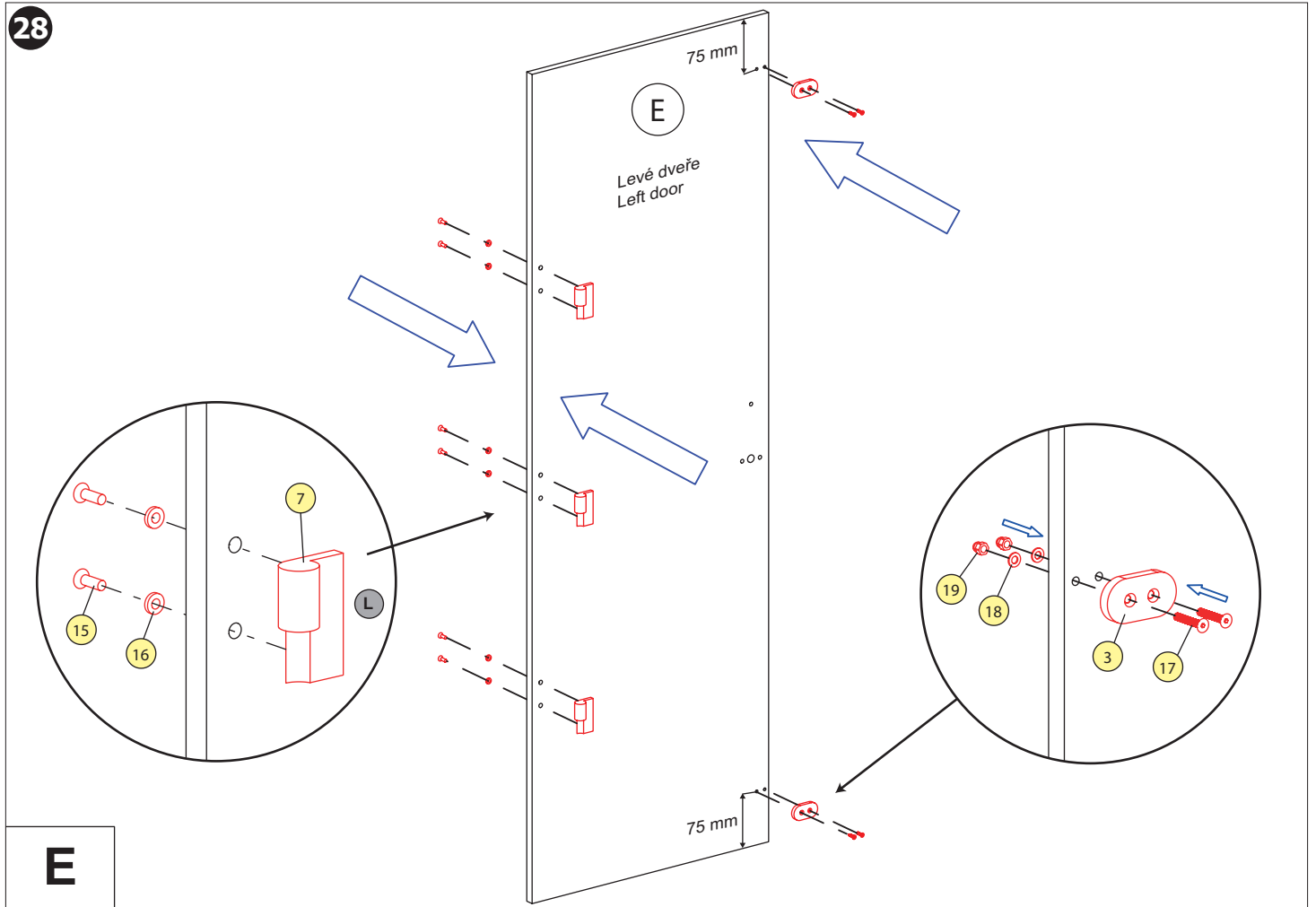

29

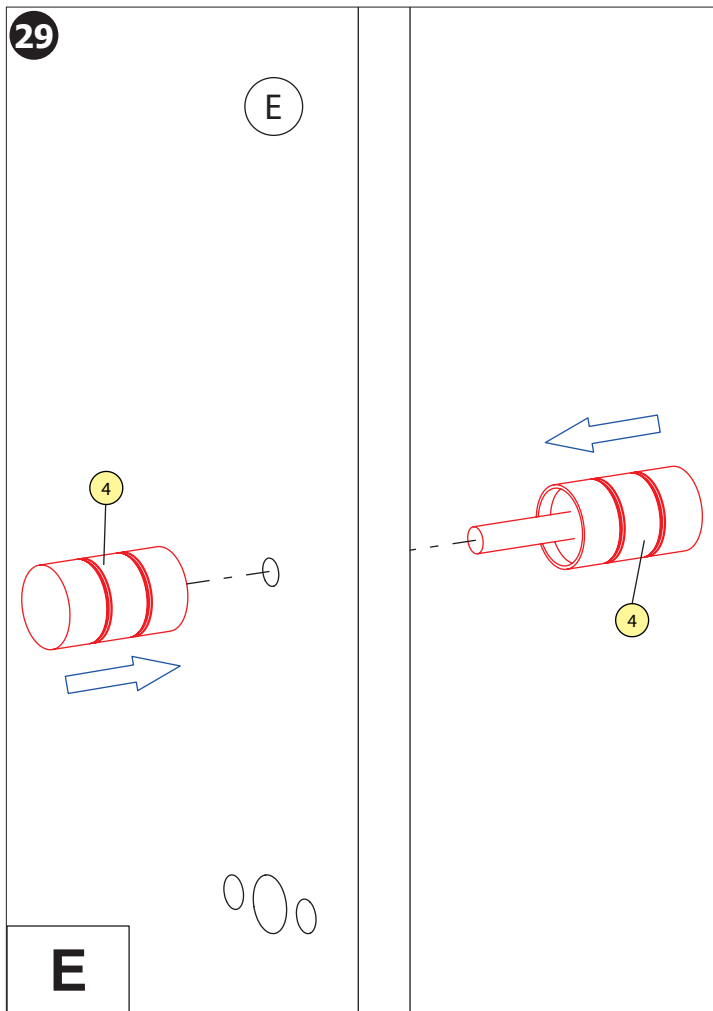

30

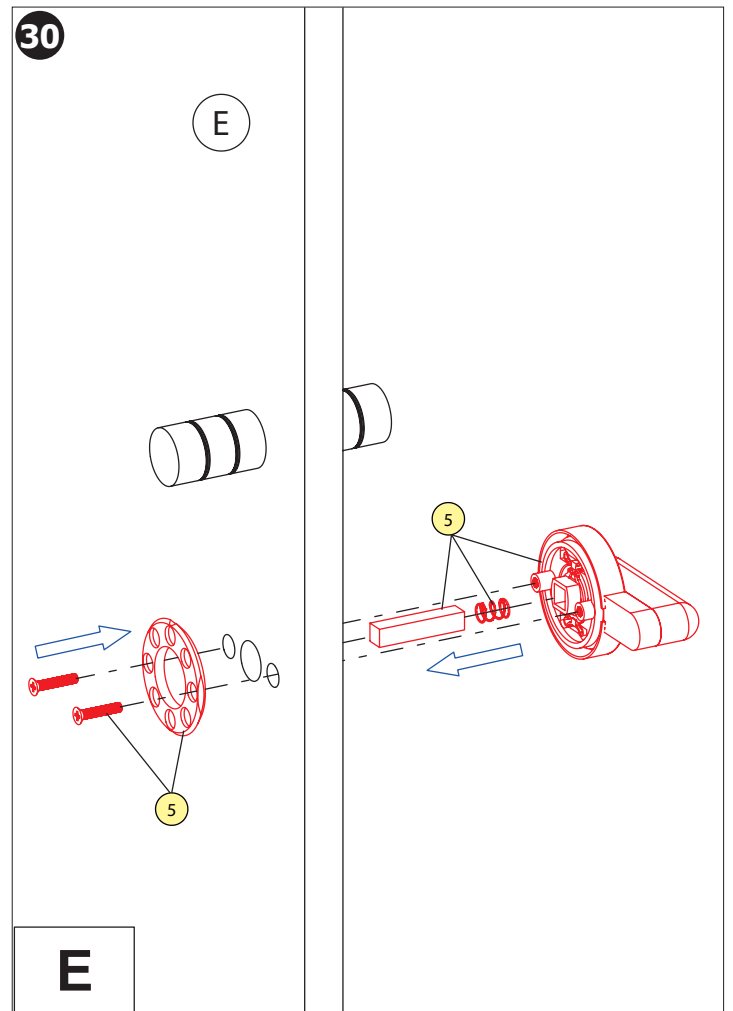

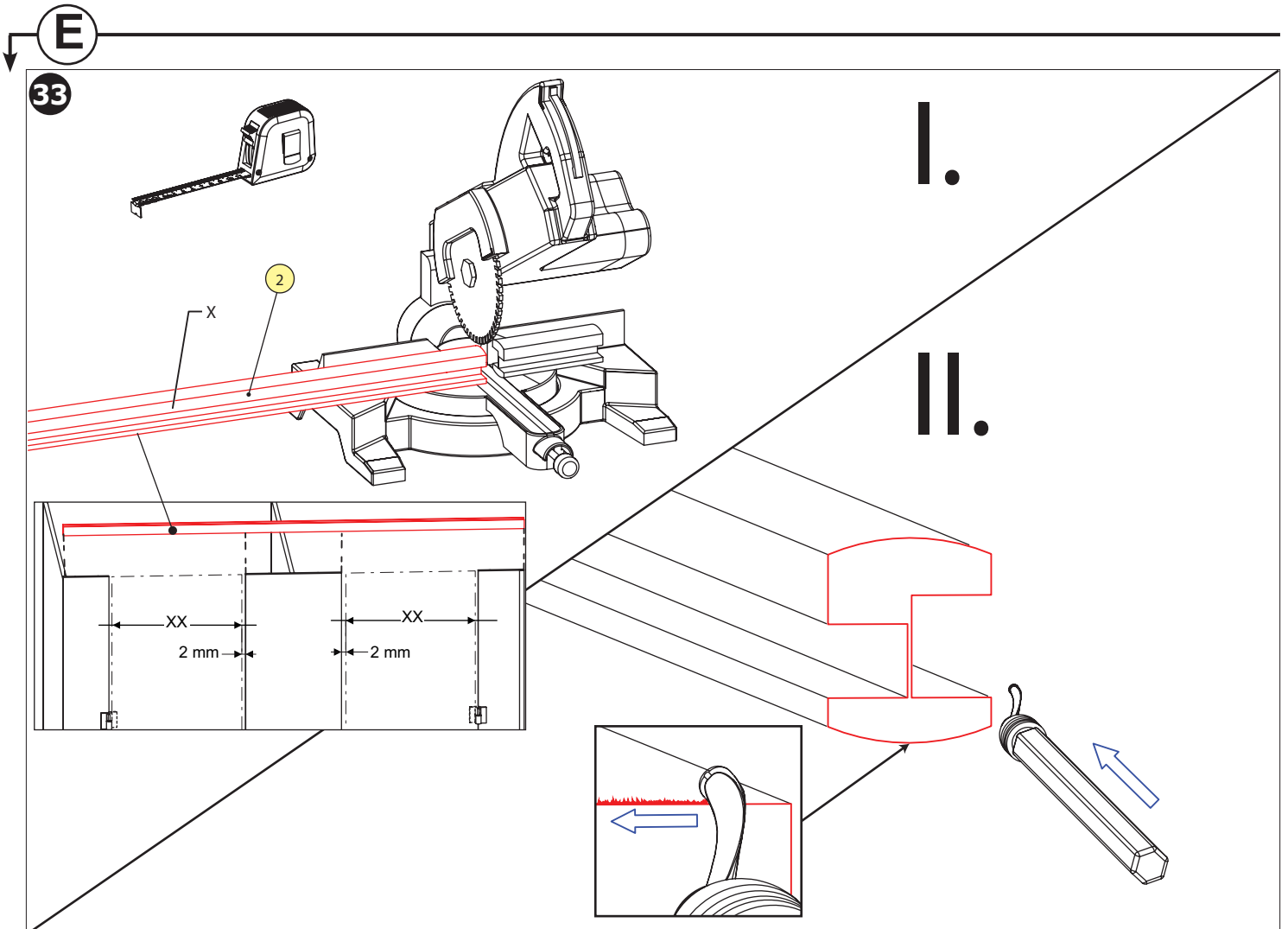
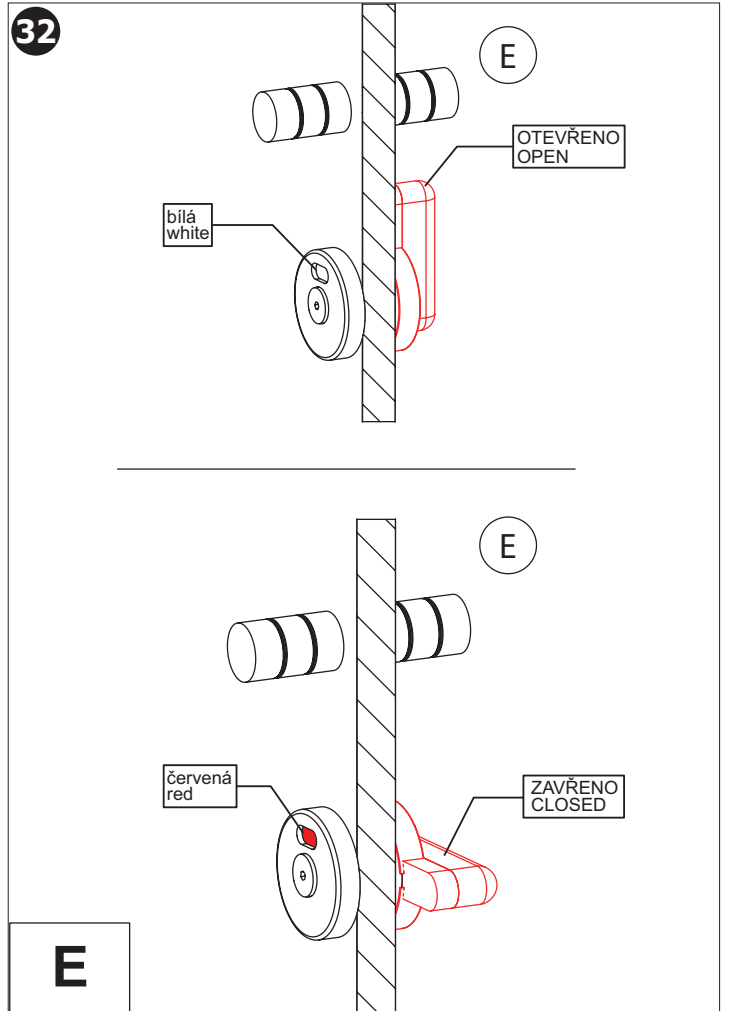
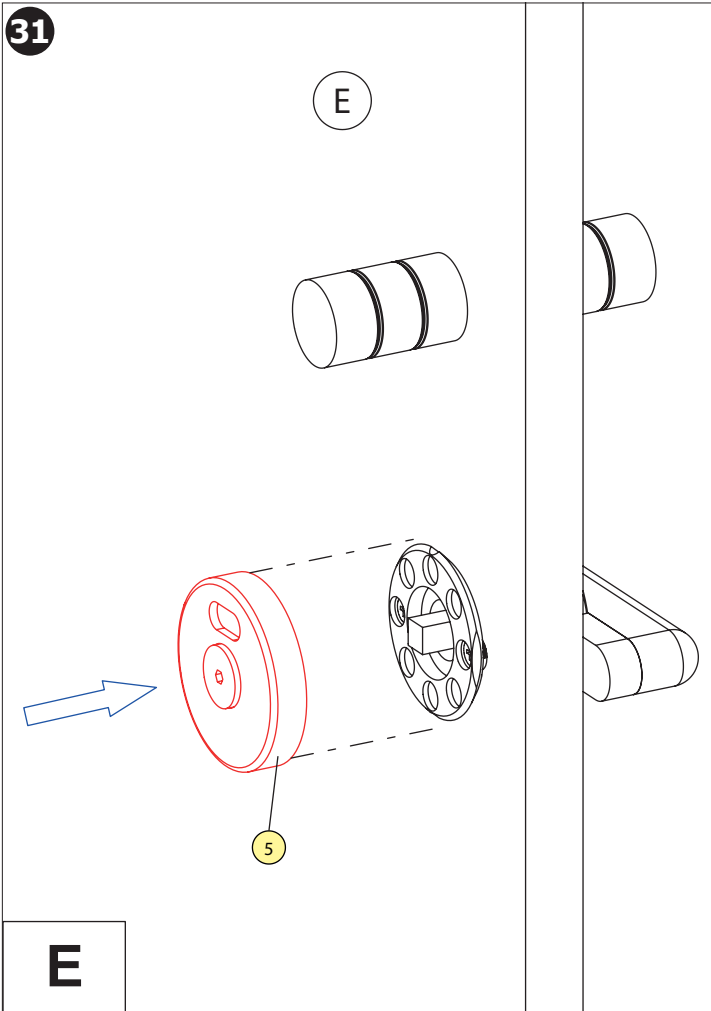

34

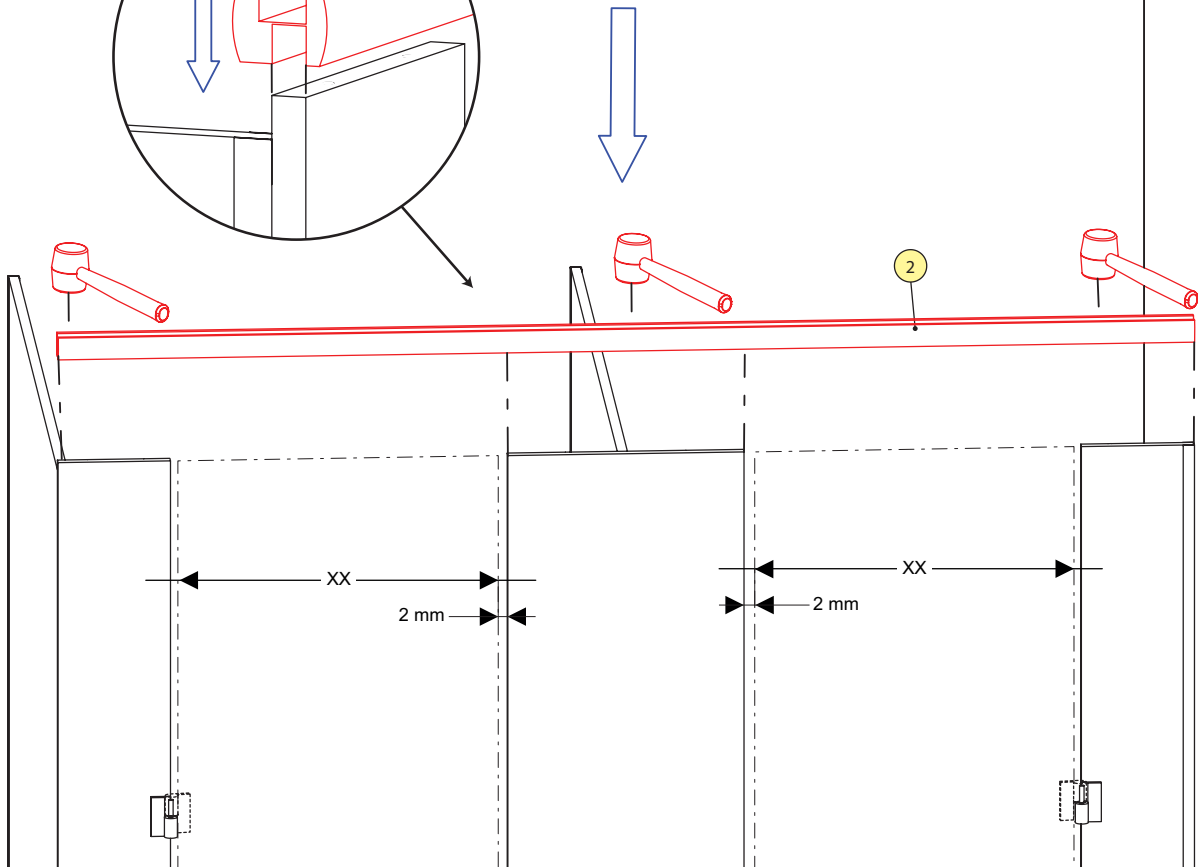
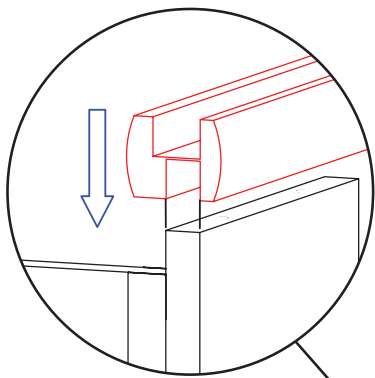

35

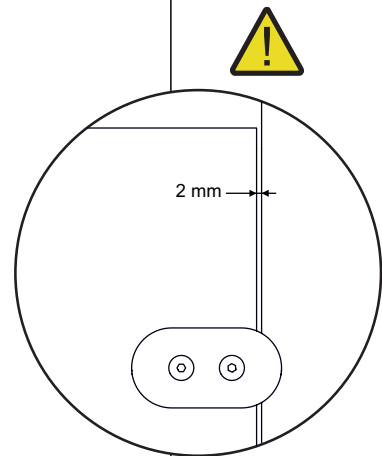
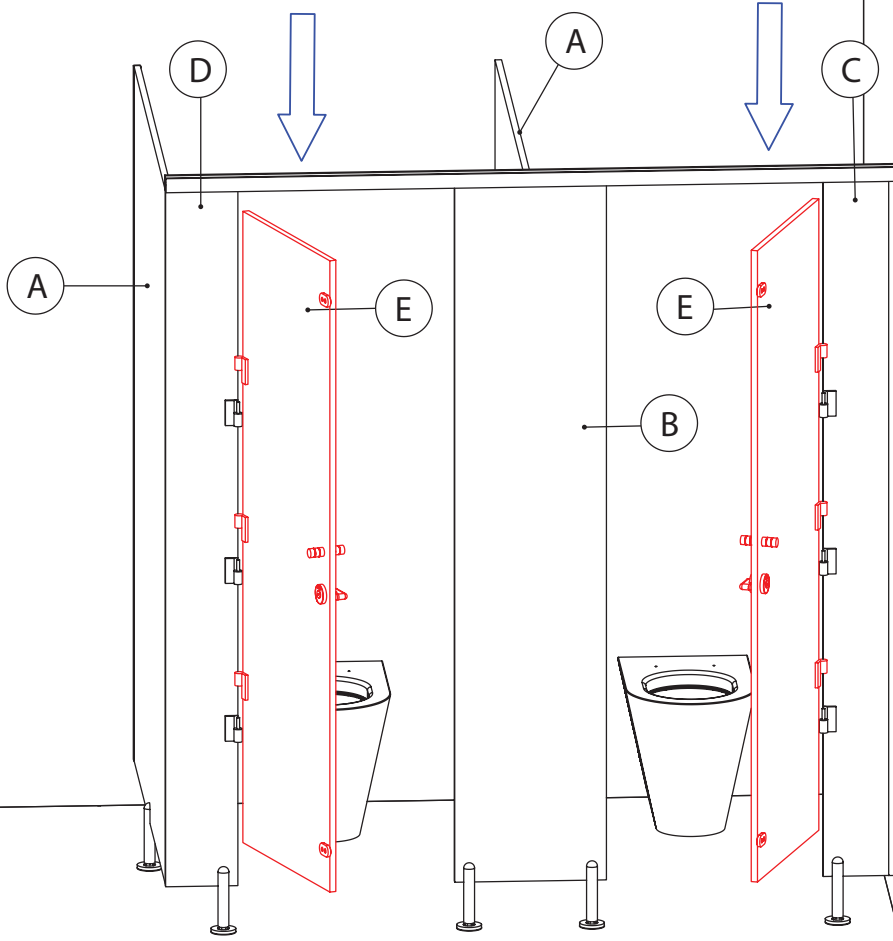

36

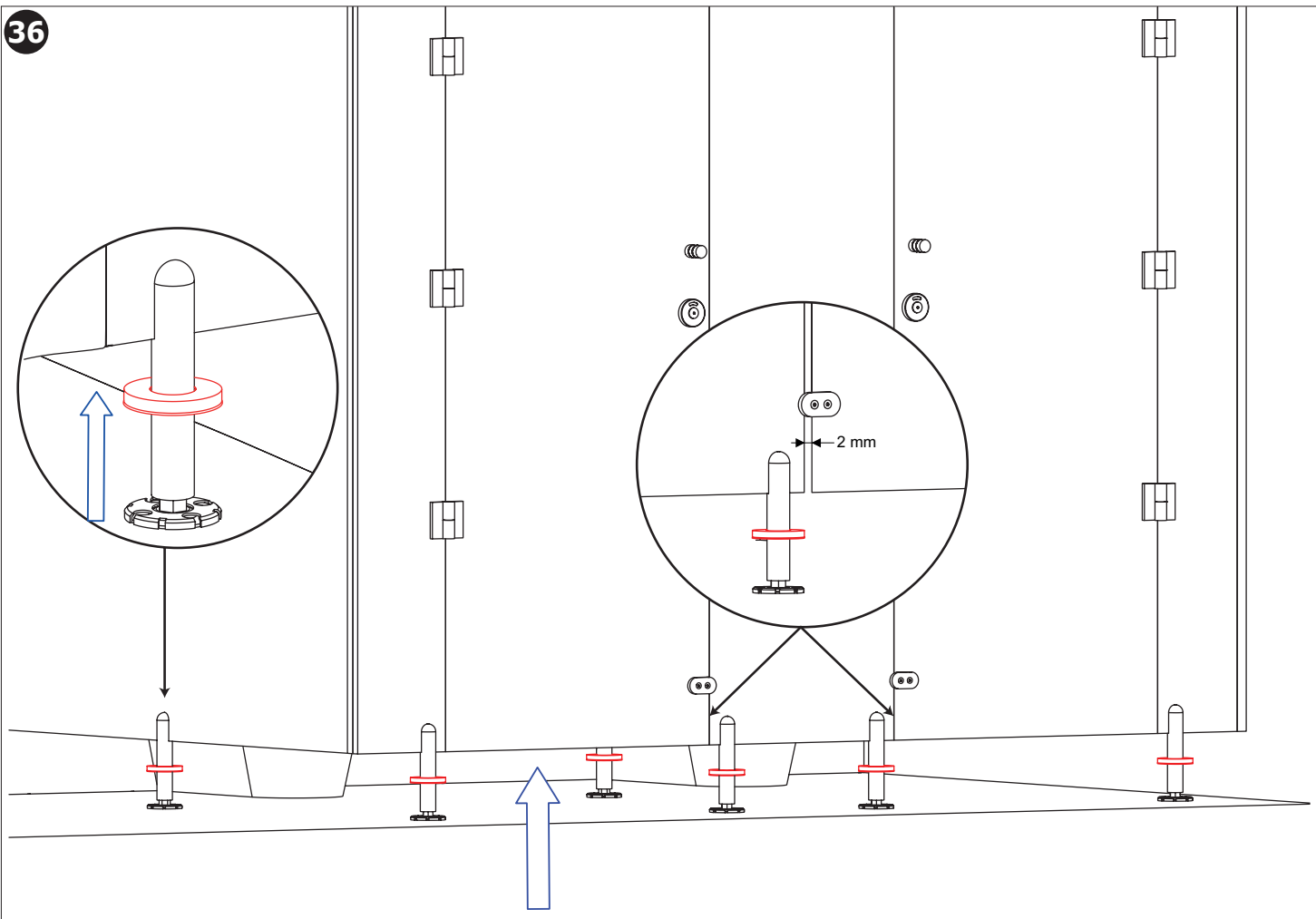

37

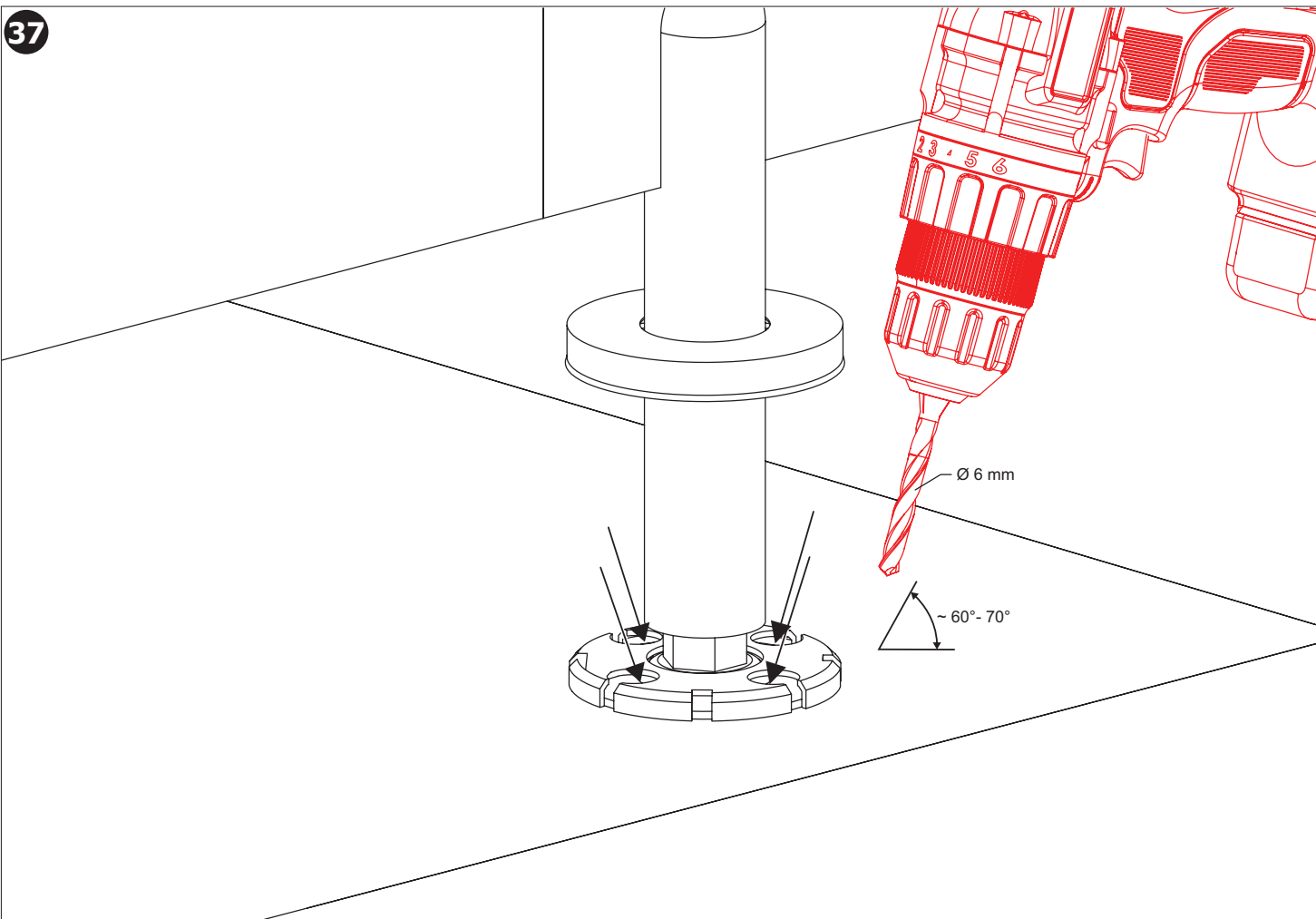

38

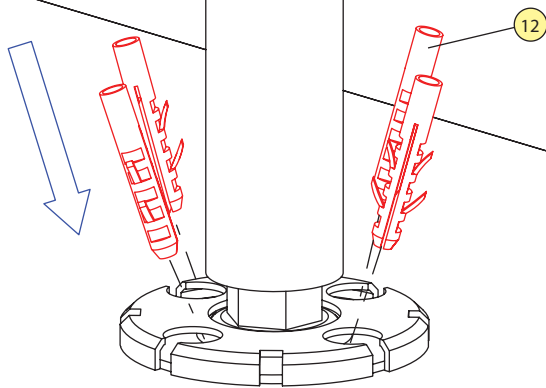

39

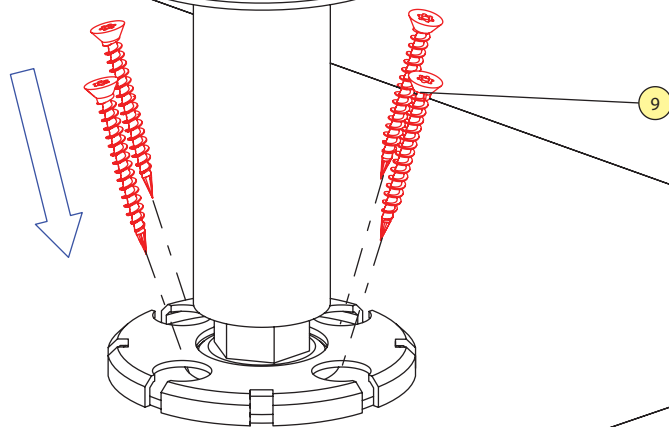

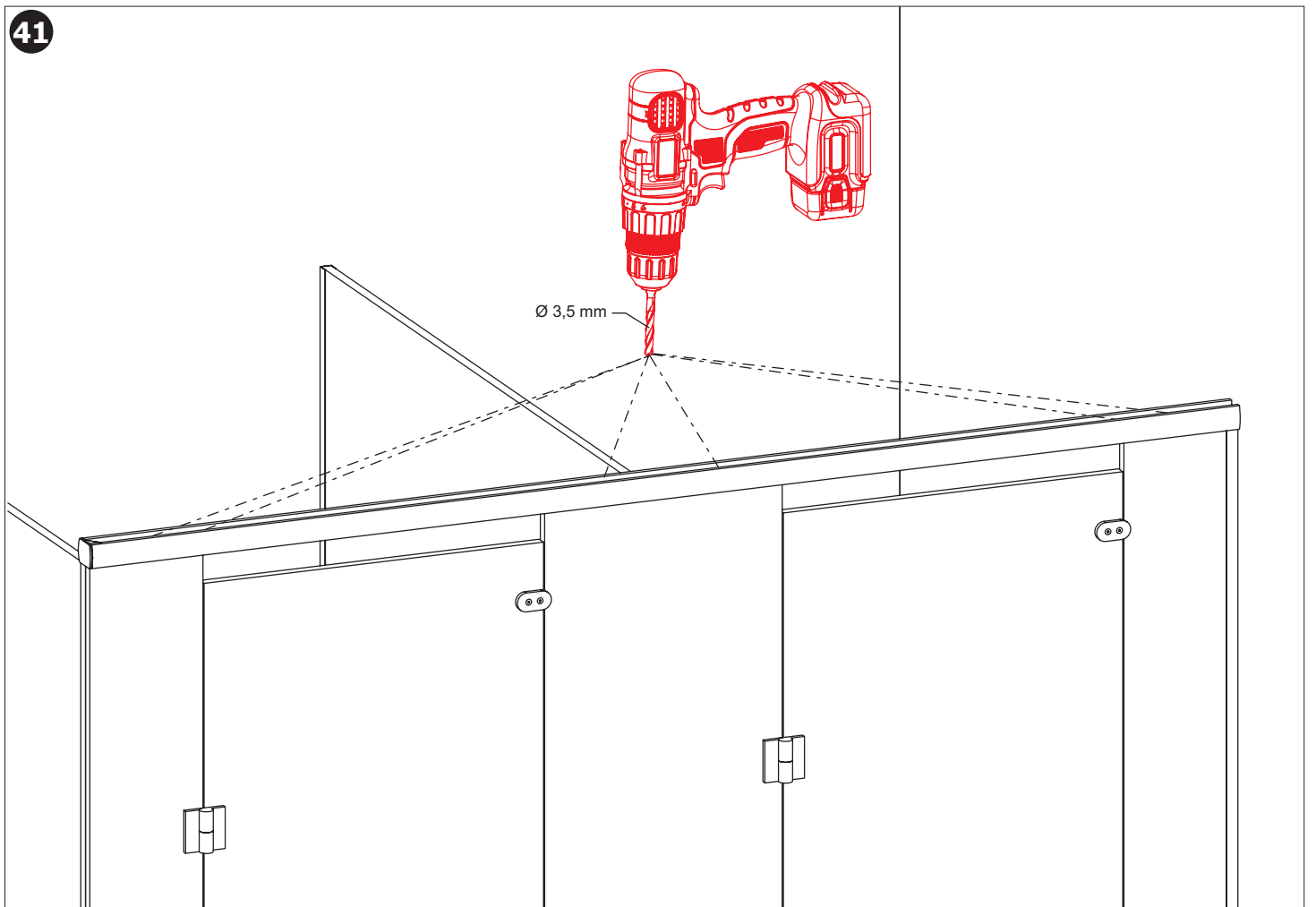
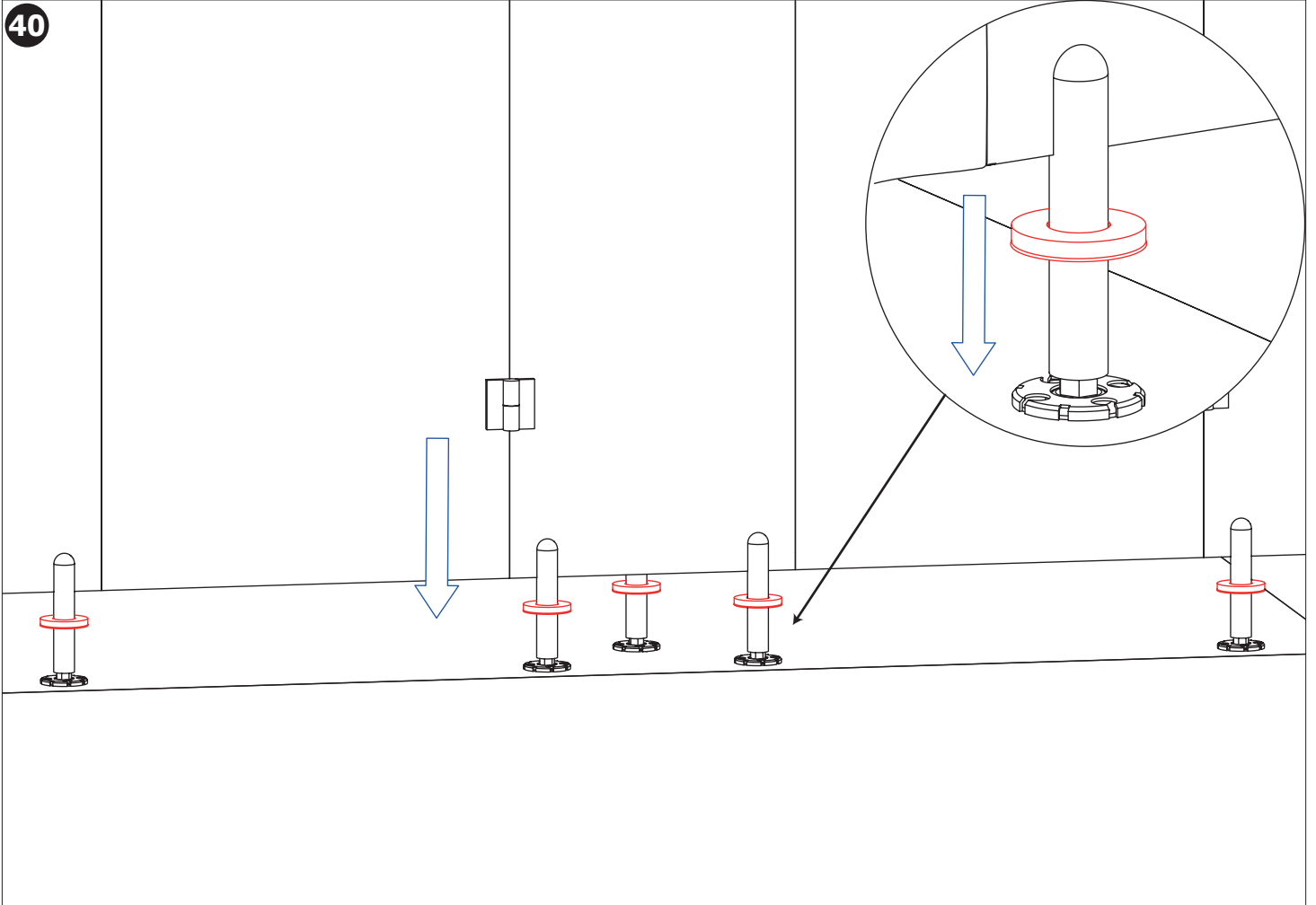

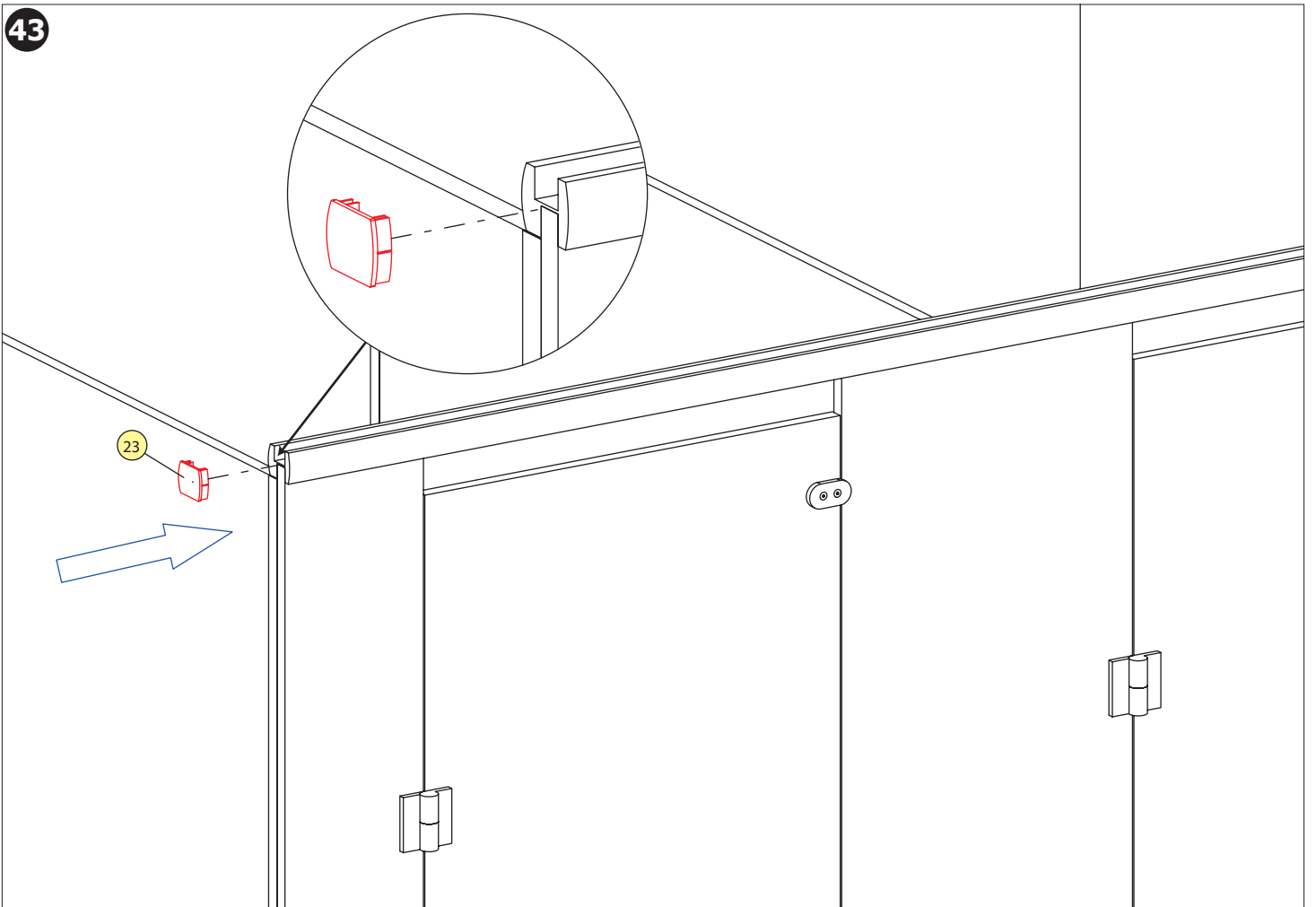
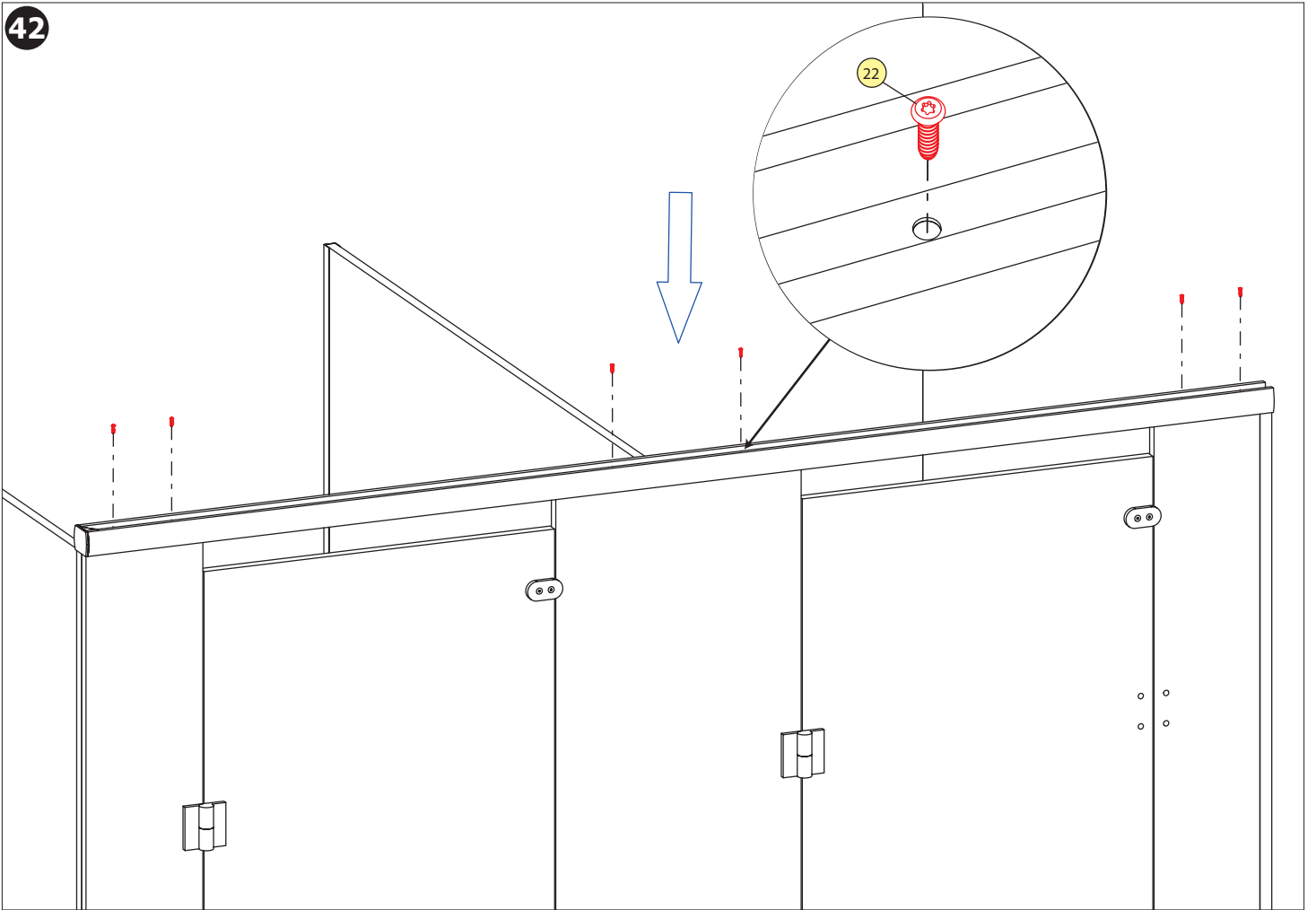

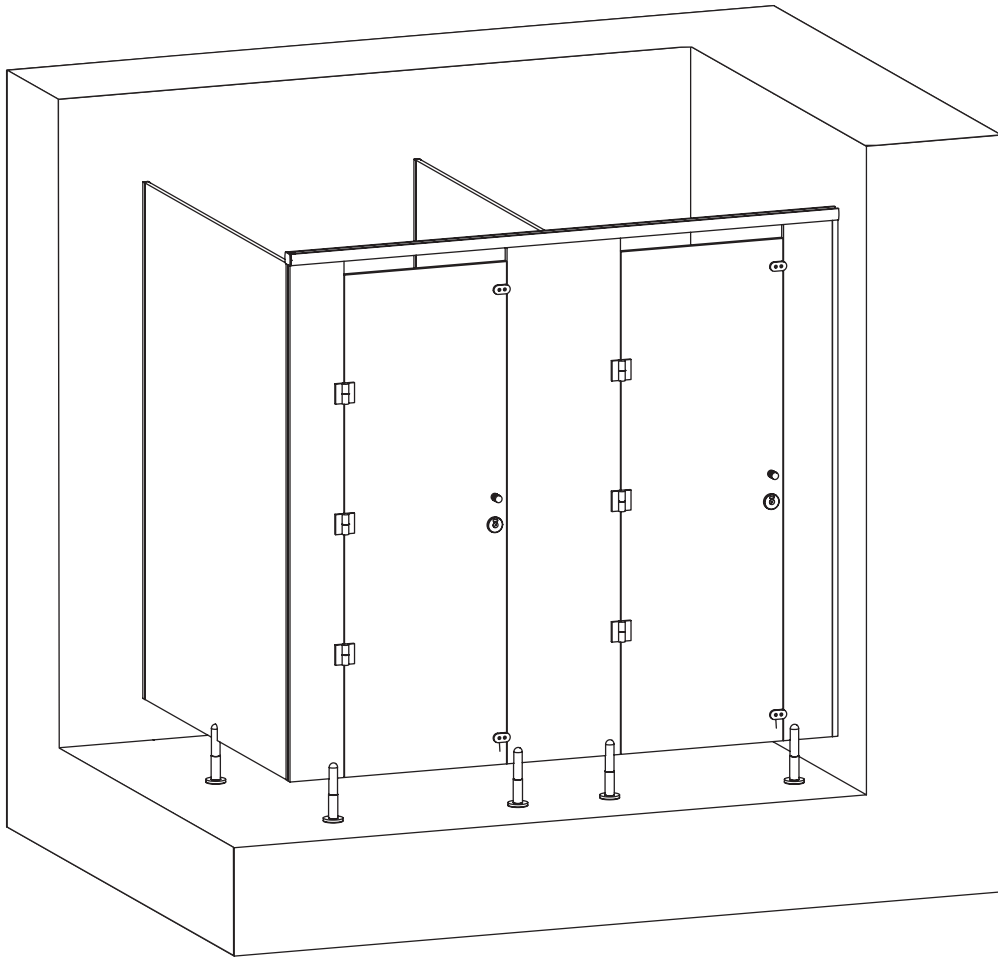

CS Specifikace dodávky
SK Špecifikácia dodávky
EN Supplied equipment

RU Спецификация поставки
DE Lieferumfang
PL Specyfikacja dostawy

RO Componente livrate
ES Especificación de suministro
FR Equipements fournis

NL Leveringsomvang
LT Tiekimo specifikacija
HU Tartozékok

SLKA 01W18A - obj. č. (Code Nr.) - 40012

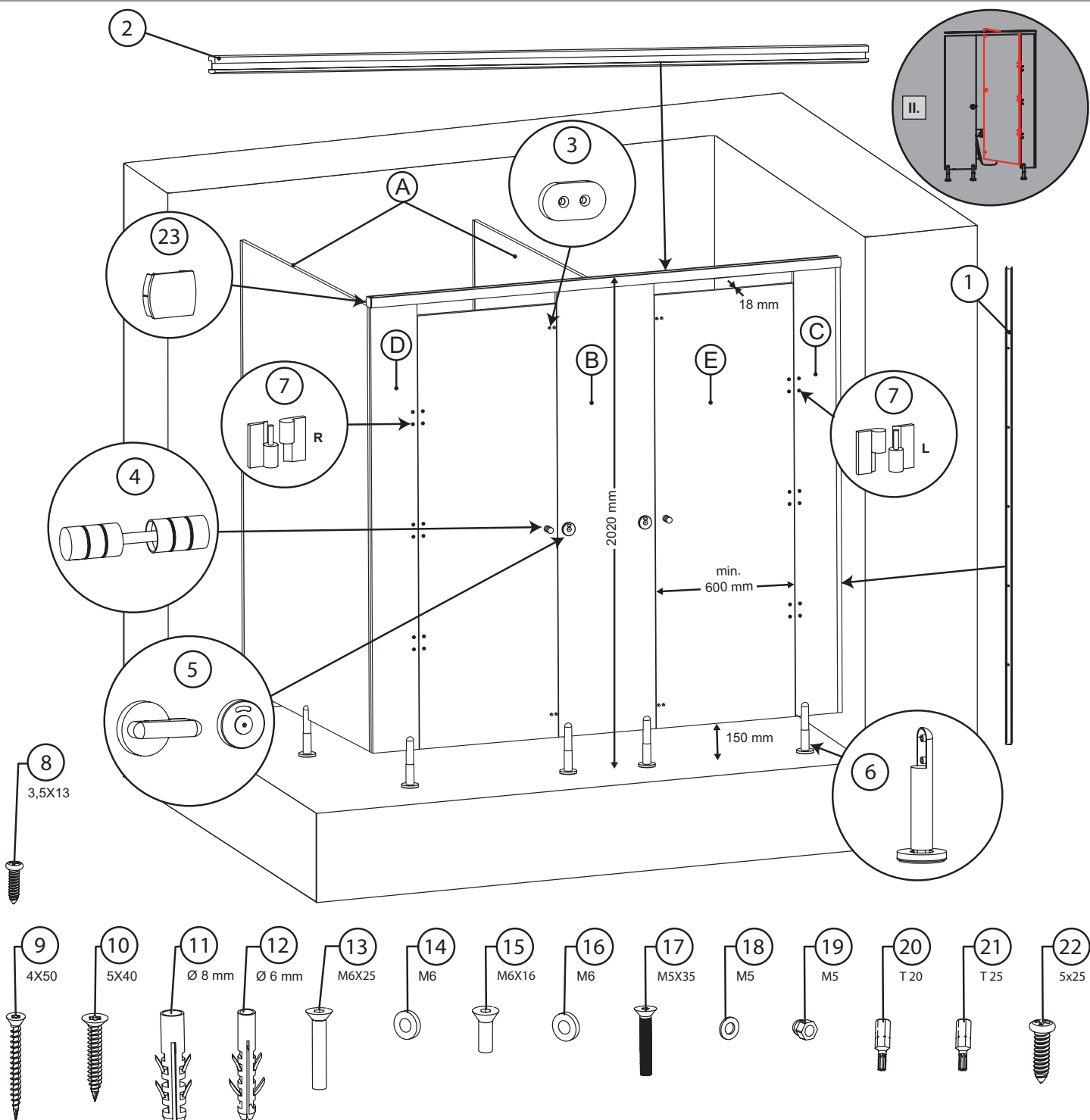

(CS) Doporučené nástroje
(SK) Odporúčané nástroje
(EN) Required tools

(RU) Рекомендуемые инструменты
(DE) Empfohlene Werkzeuge
(PL) Zalecane narzędzia

(RO) Instrumente recomandate
(ES) Herramientas recomendadas
(FR) Outils recommandés

(NL) Aanbevolen tools
(LT) Rekomenduojami įrankiai
(HU) Ajánlott eszközök

 2 osoby
2 person

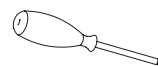
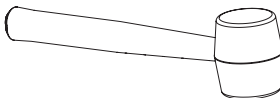
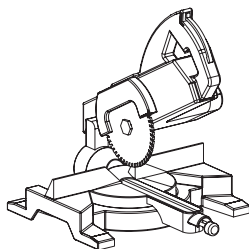
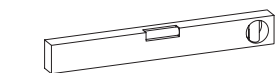
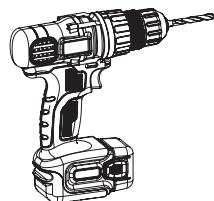

(CS) Instalace
(SK) Inštalácia
(EN) Installation

(RU) Схема включения и монтажа
(DE) Installation
(PL) Instalacja

(RO) Instalare
(ES) Instalación
(FR) Installation

(NL) Installatie
(LT) Montavimo ir įjungimo schema
(HU) Beüzemelés

Varianta otevírání / Opening option: **II.** → dovnitř / inward

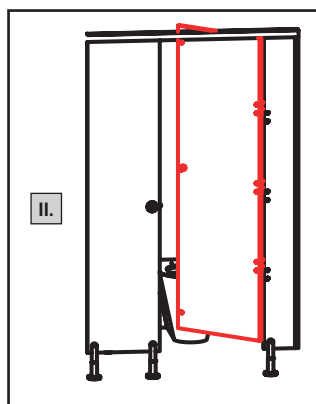

UPOZORNĚNÍ

Prvním krokem je rozměření prostoru montáže, zohlednění nerovností stávajících konstrukcí, prověření materiálu nosných stěn, do kterých bude konstrukce kotvena, popřípadě materiálu obkladu stěn a zvolení tomu odpovídajícího náčiní. Nutno prověřit místa rozvodu médií v navazujících konstrukcích – voda, elektroinstalace a podobně. Pokud je v místnosti podlahové vytápění, rektifikační nohy k podkladu přilepíme vhodným lepidlem.

WARNING

The first step is to measure the installation area, take into account the imperfections of the existing structures, check the material of the supporting walls into which the framework will be anchored, or the material of the wall tiling, and choose the appropriate tools. It is necessary to check the locations of the supply of mediums in the surrounding structures - water, wiring, etc. If there is underfloor heating in the room, glue the rectification legs to the floor with a suitable adhesive.



CS – Před instalací je nezbytné důkladně se seznámit s příloženými Bezpečnostními pokyny.

EN – Before installation, it is essential to thoroughly familiarize yourself with the attached Safety Instructions.

SK – Pred inštaláciou je nevyhnutné dôkladne sa oboznámiť s priloženými Bezpečnostnými pokynmi.

RU – Перед установкой необходимо внимательно ознакомиться с приложенными инструкциями по безопасности.

DE – Vor der Installation ist es erforderlich, sich gründlich mit den beigefügten Sicherheitsanweisungen vertraut zu machen.

PL – Przed instalacją konieczne jest dokładnie zapoznanie się z dołączonymi instrukcjami bezpieczeństwa.

RO – Înainte de instalare, este necesar să vă familiarizați temeinic cu instrucțiunile de siguranță atașate.

ES – Antes de la instalación, es esencial familiarizarse a fondo con las instrucciones de seguridad adjuntas.

FR – Avant l'installation, il est indispensable de bien prendre connaissance des instructions de sécurité jointes.

NL – Voor de installatie is het noodzakelijk om de bijgevoegde veiligheidsinstructies zorgvuldig door te lezen.

LT – Prieš montavimą būtina atidžiai susipažinti su pridėtomis saugos instrukcijomis.

HU – A telepítés előtt elengedhetetlen, hogy alaposan megismerkedjen a mellékelt biztonsági utasításokkal.

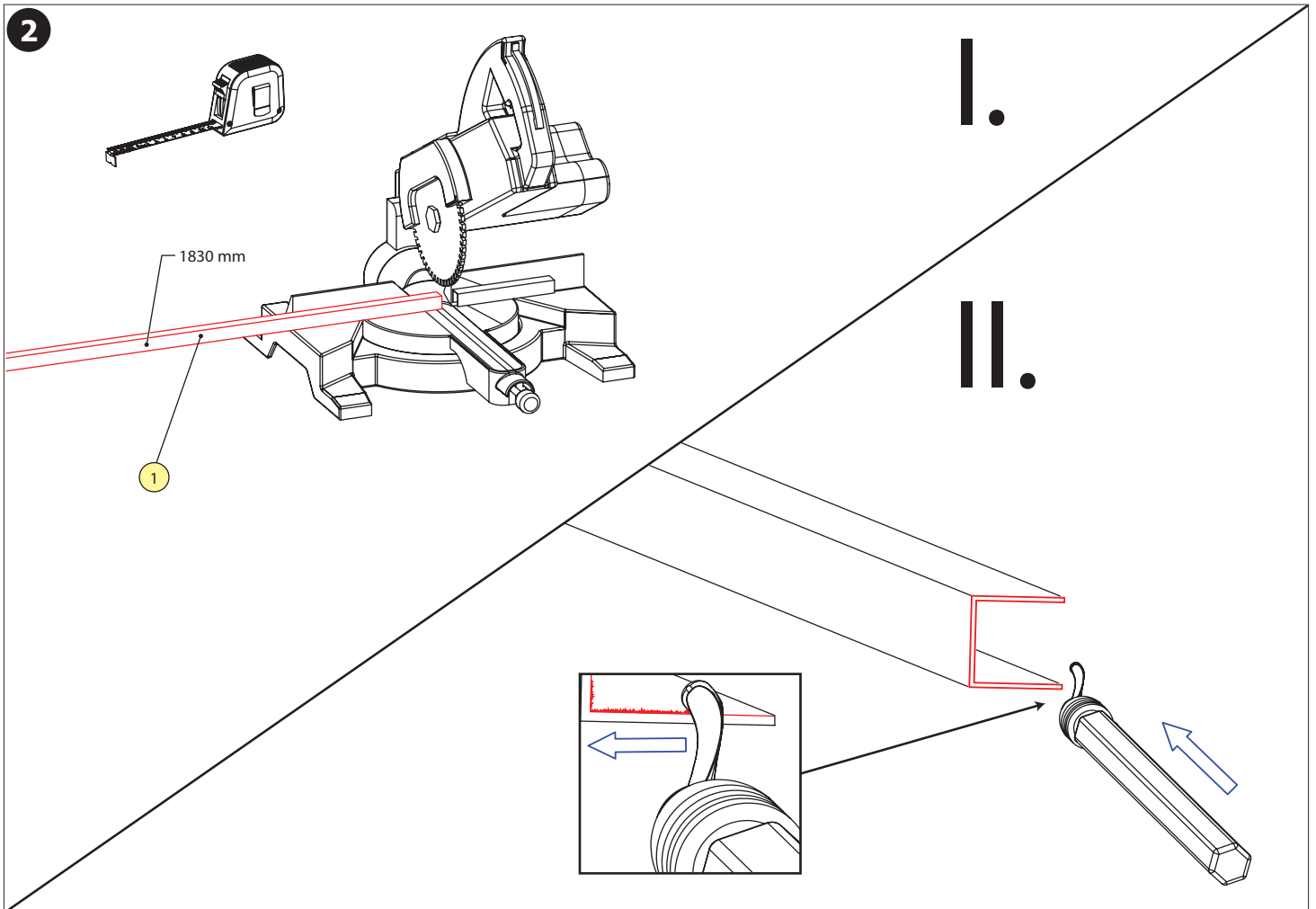
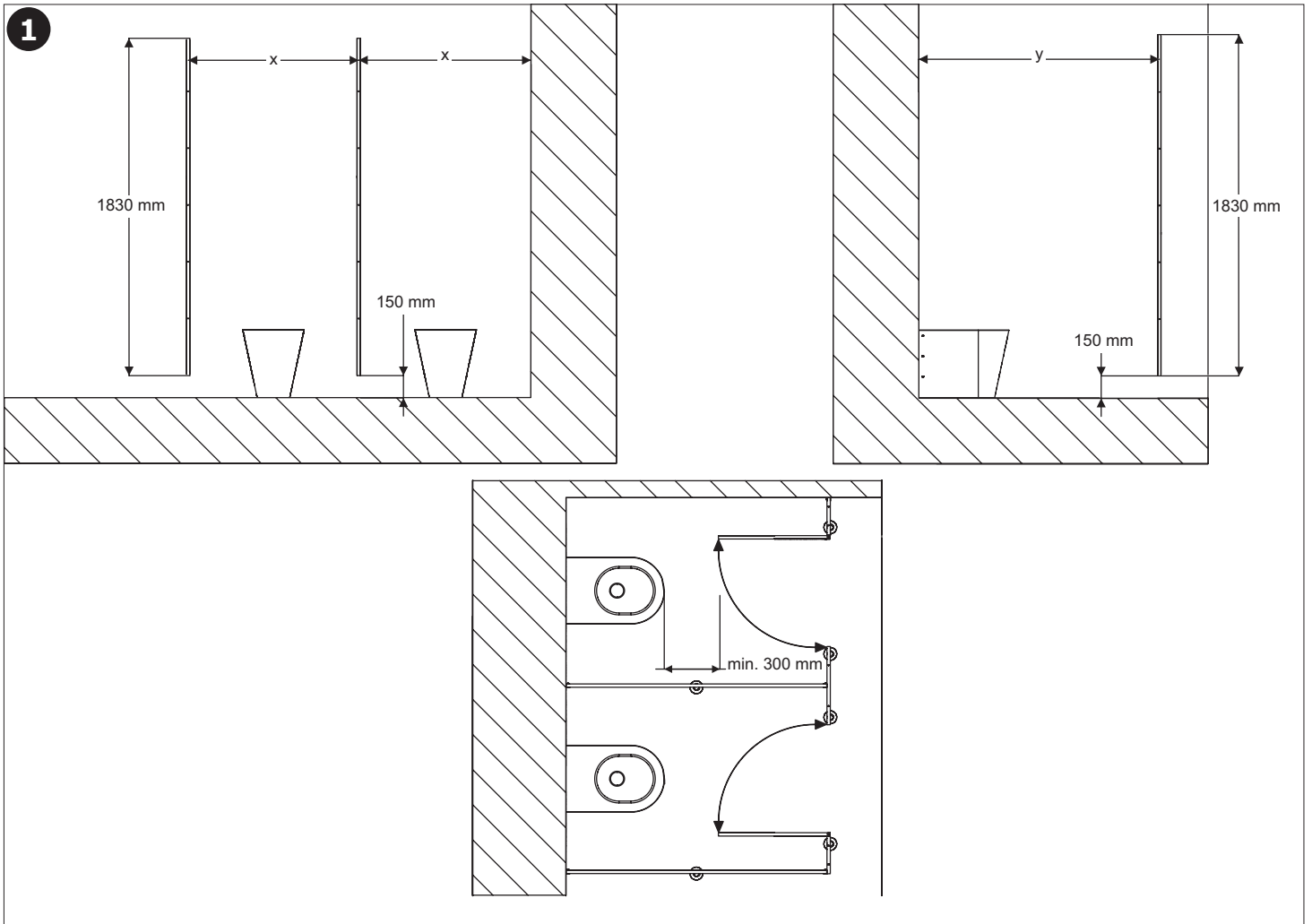

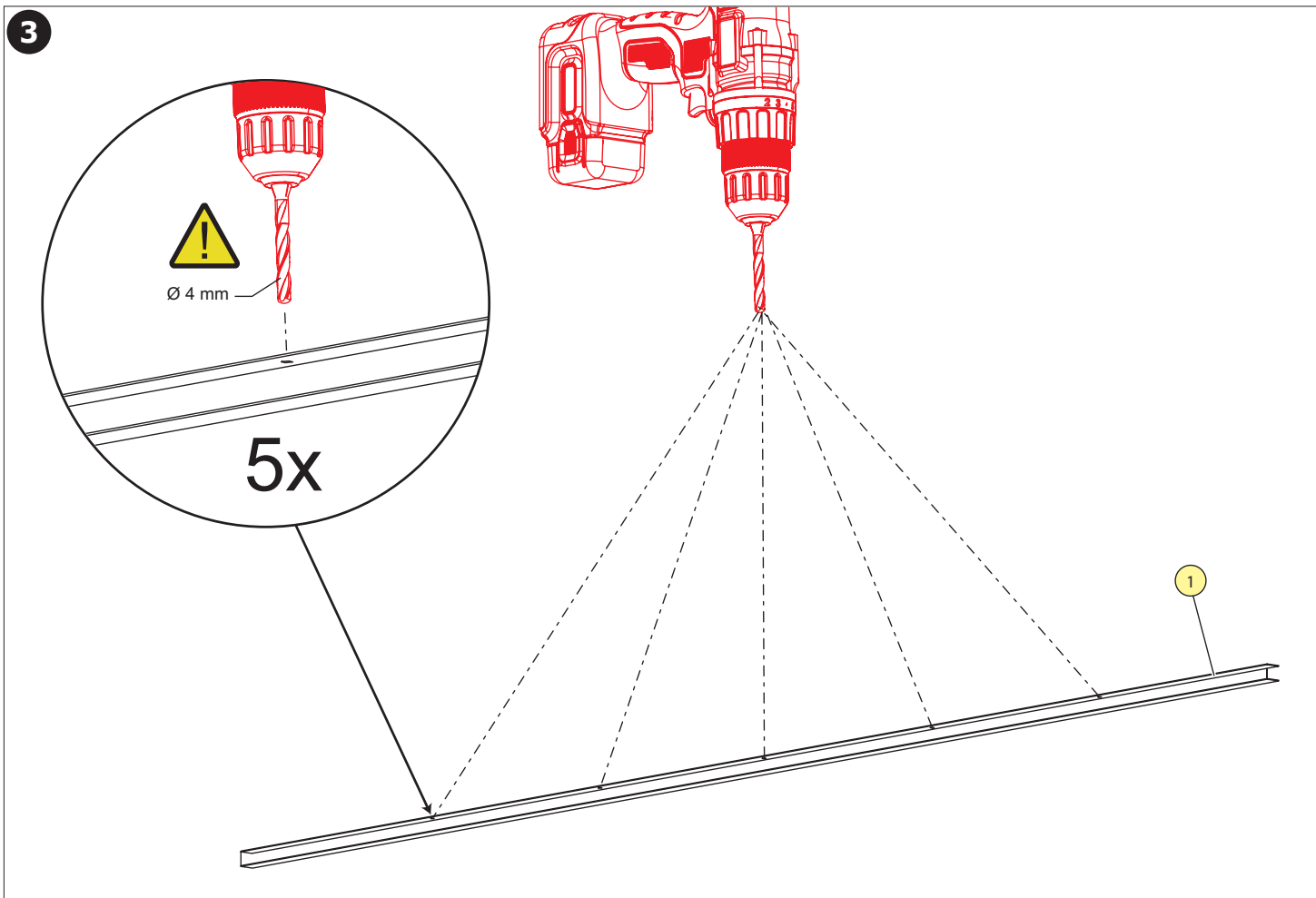

Rozdělení profilu / Profile segmentation: **A** → stěnový profil / wall profile
B → profil středové desky / central plate profile

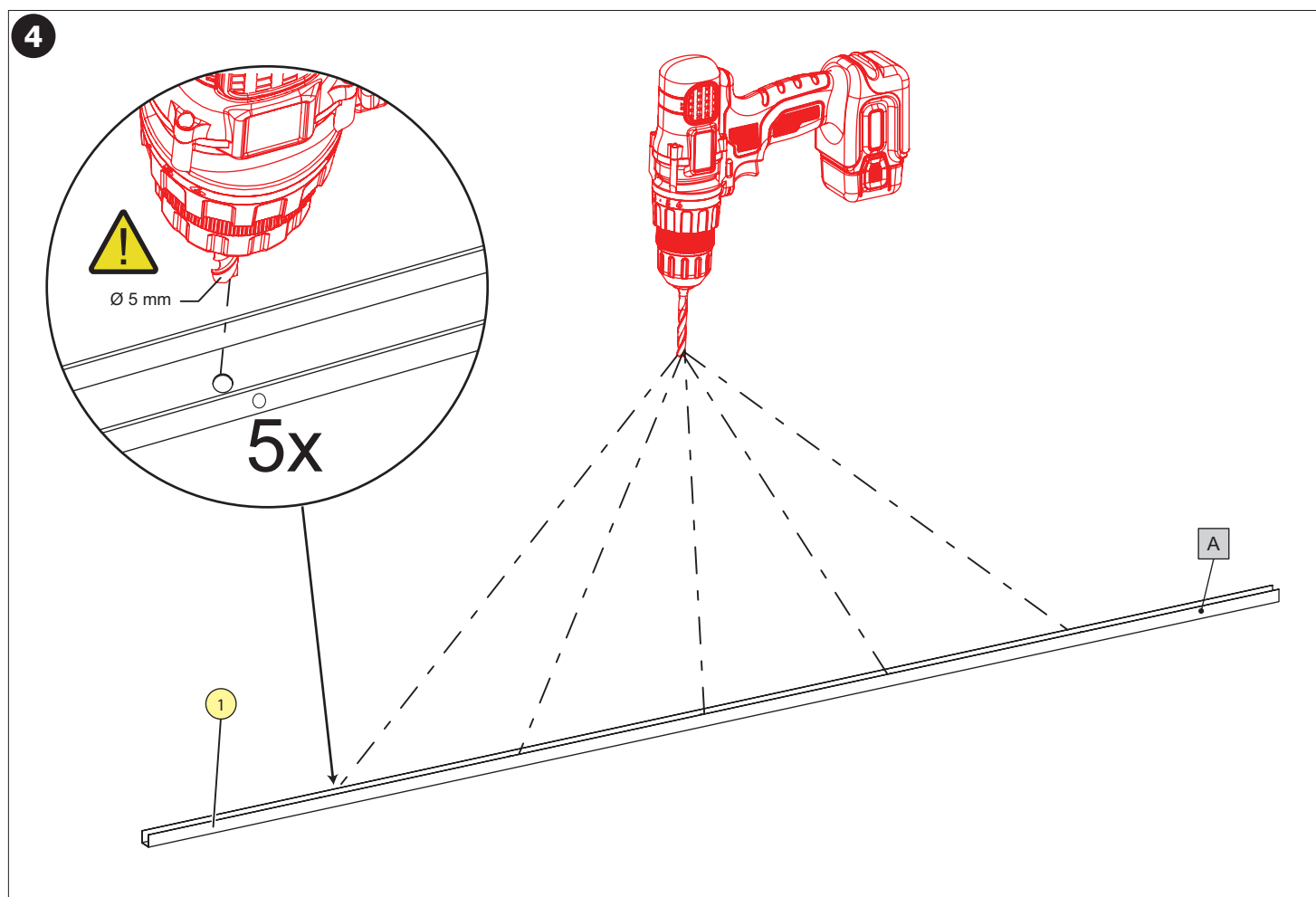

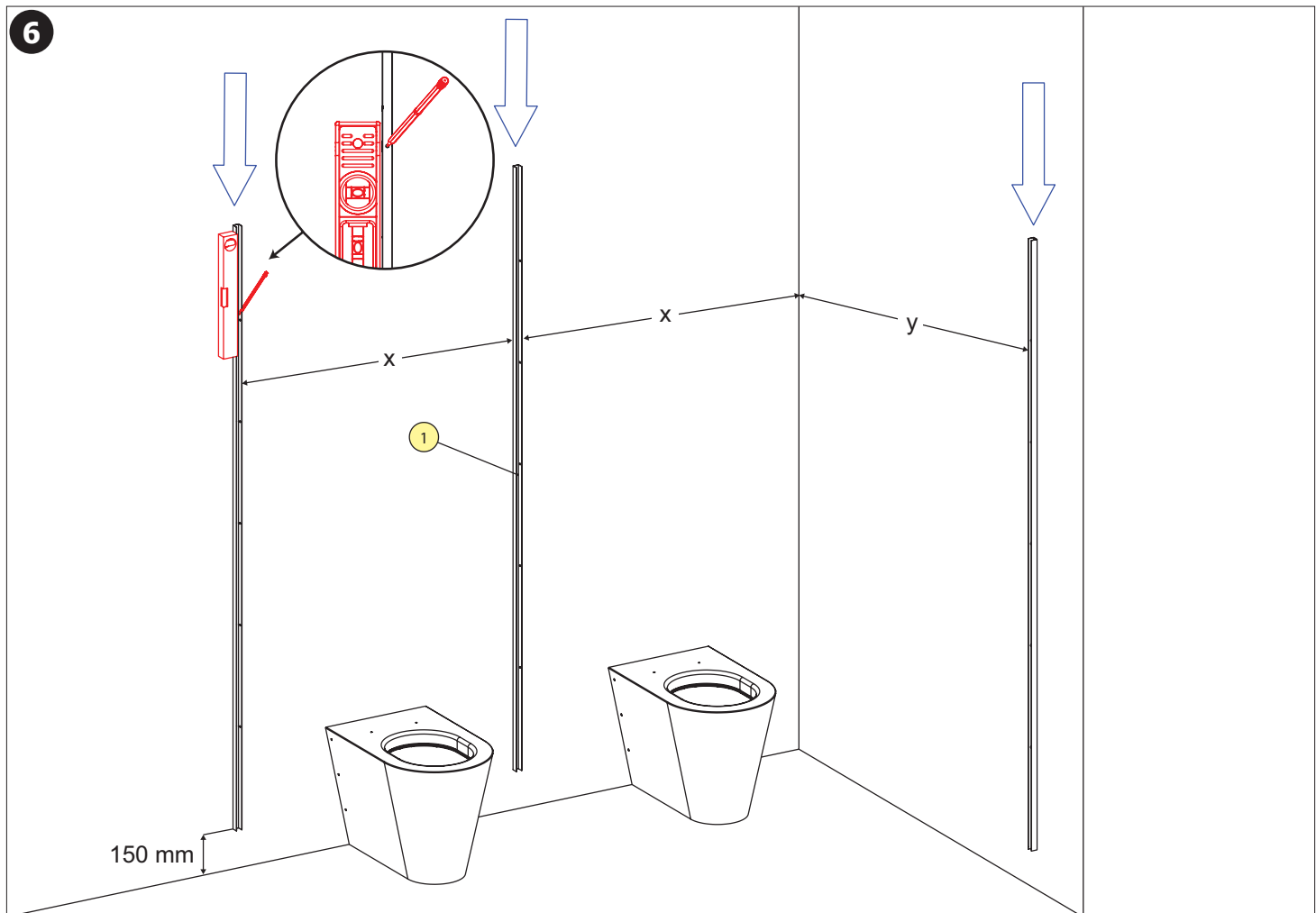
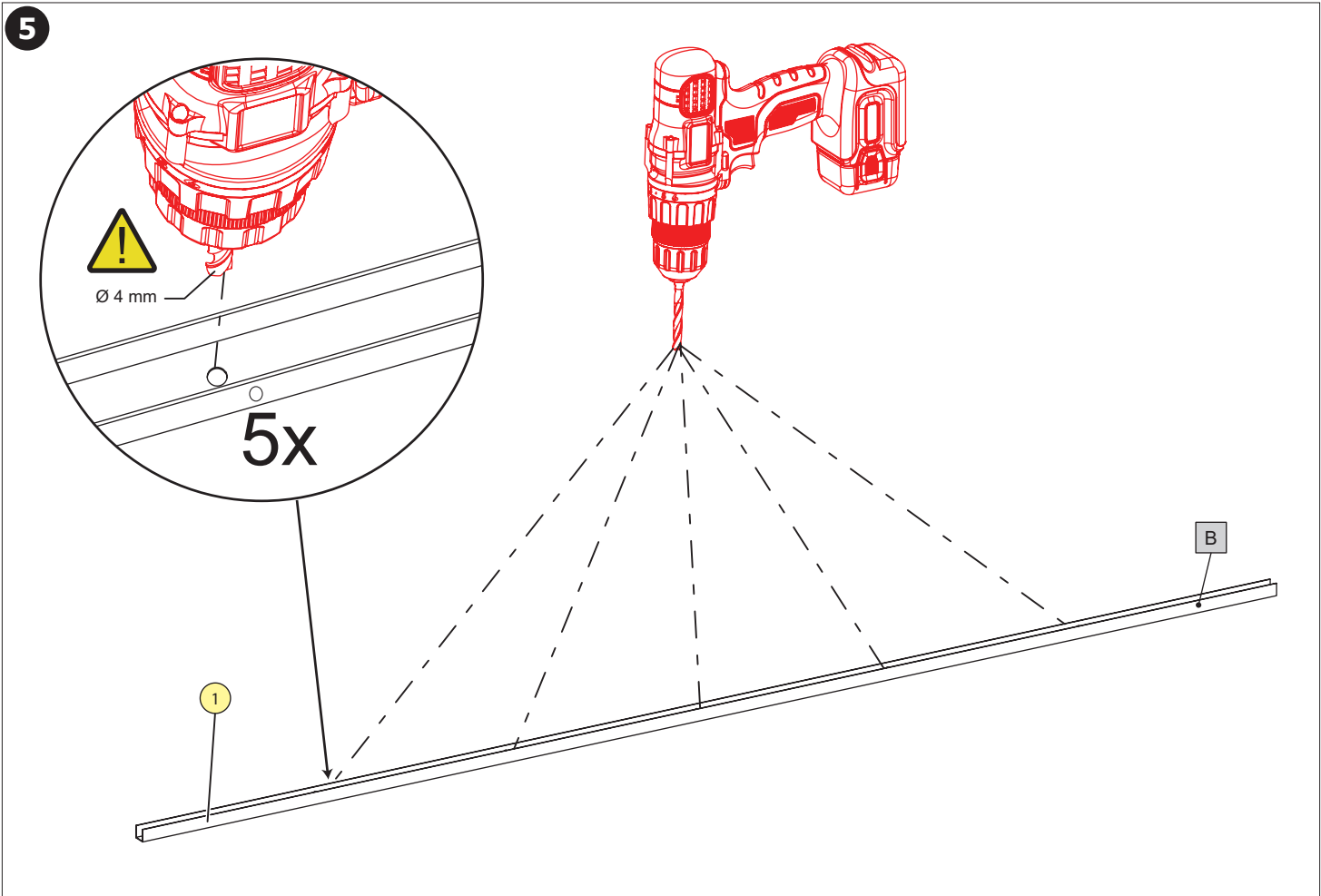

7

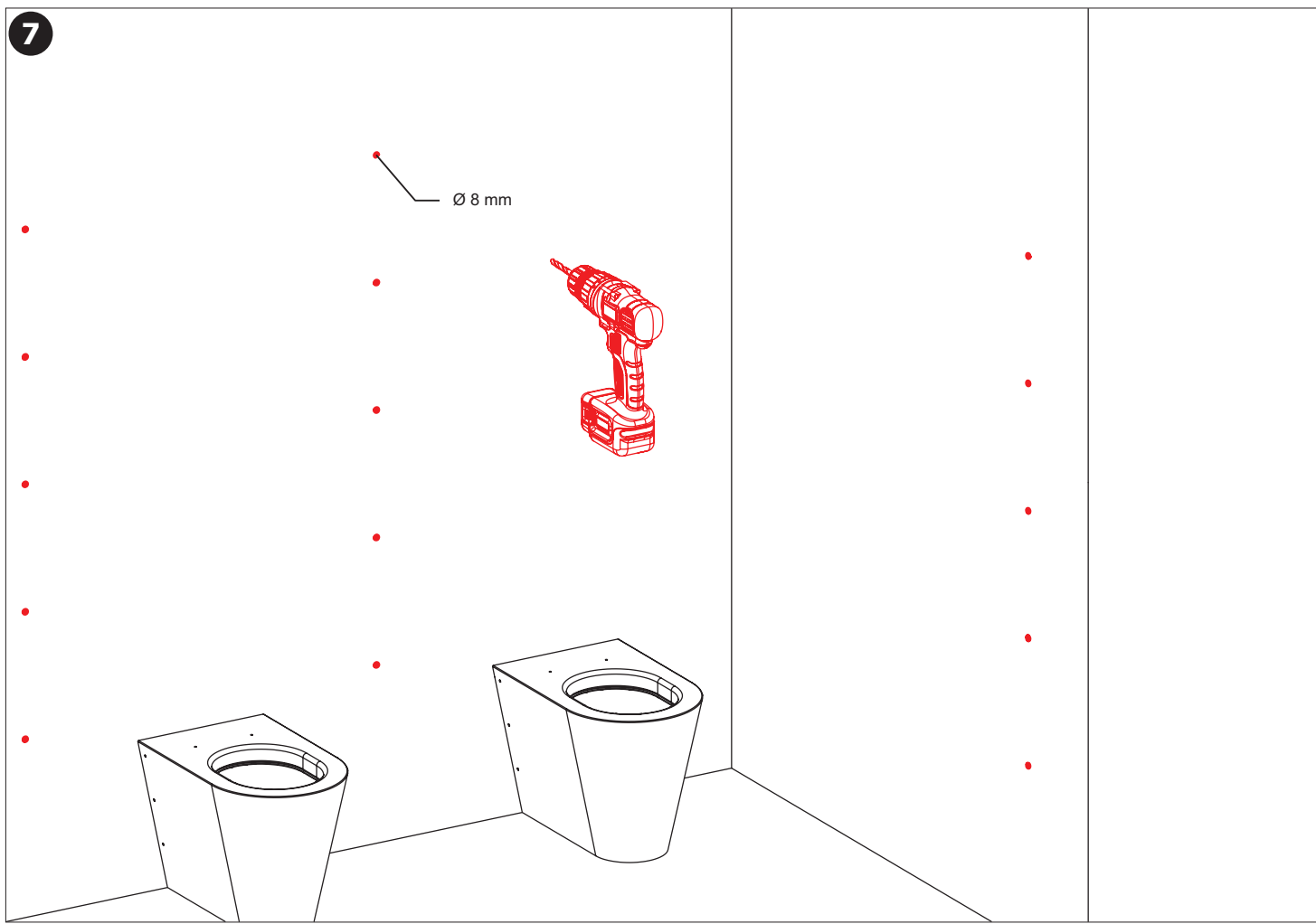

8

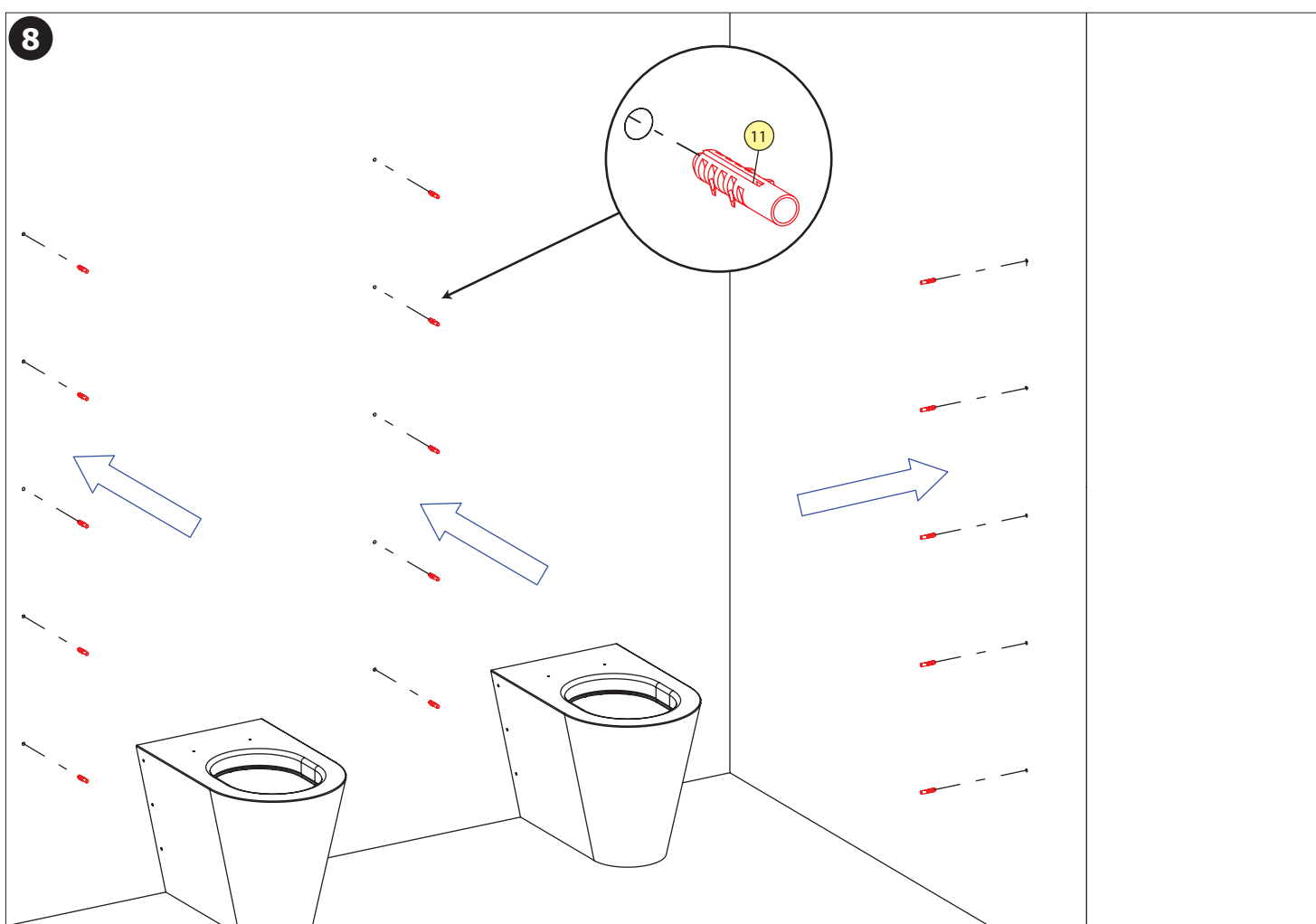

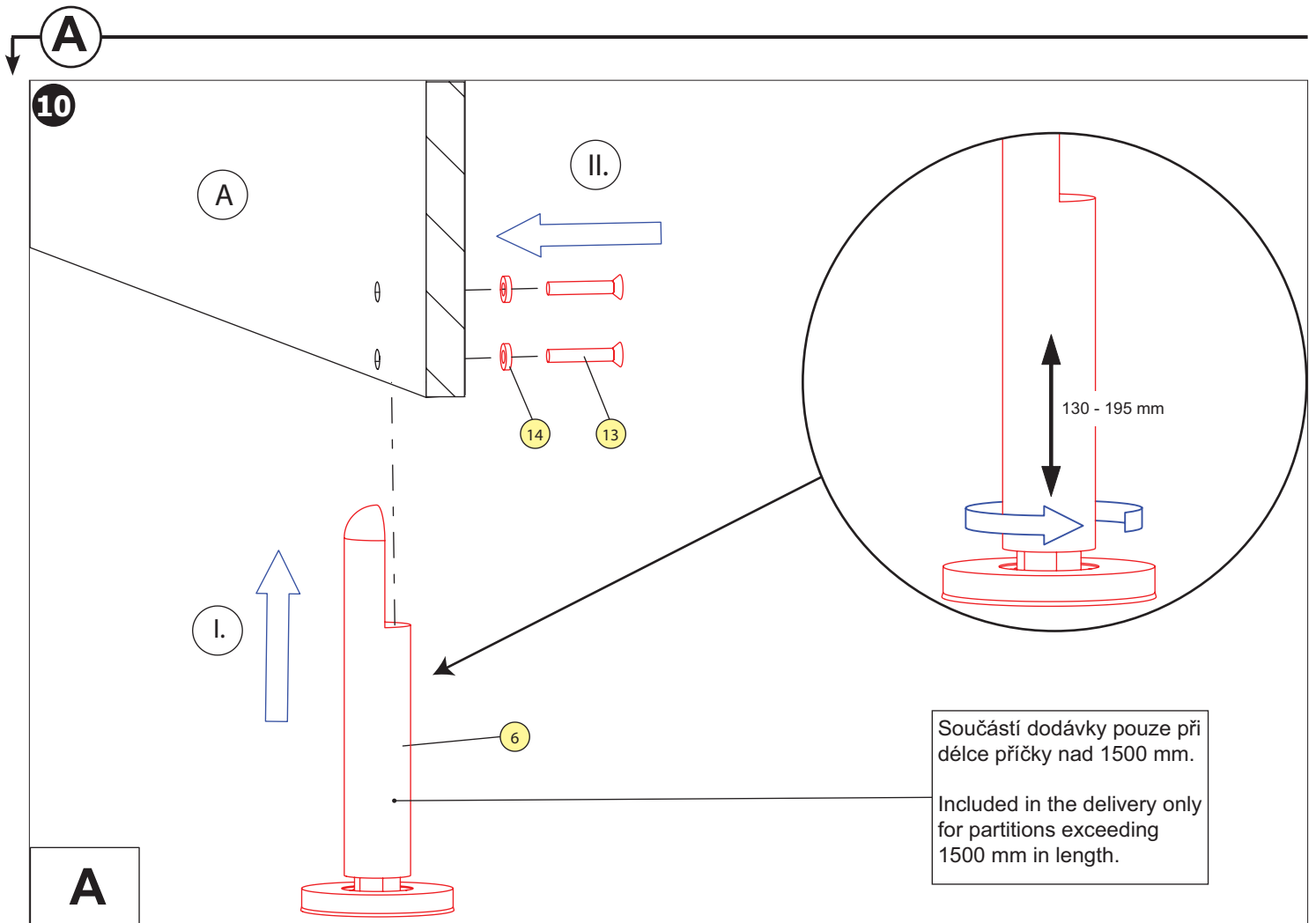
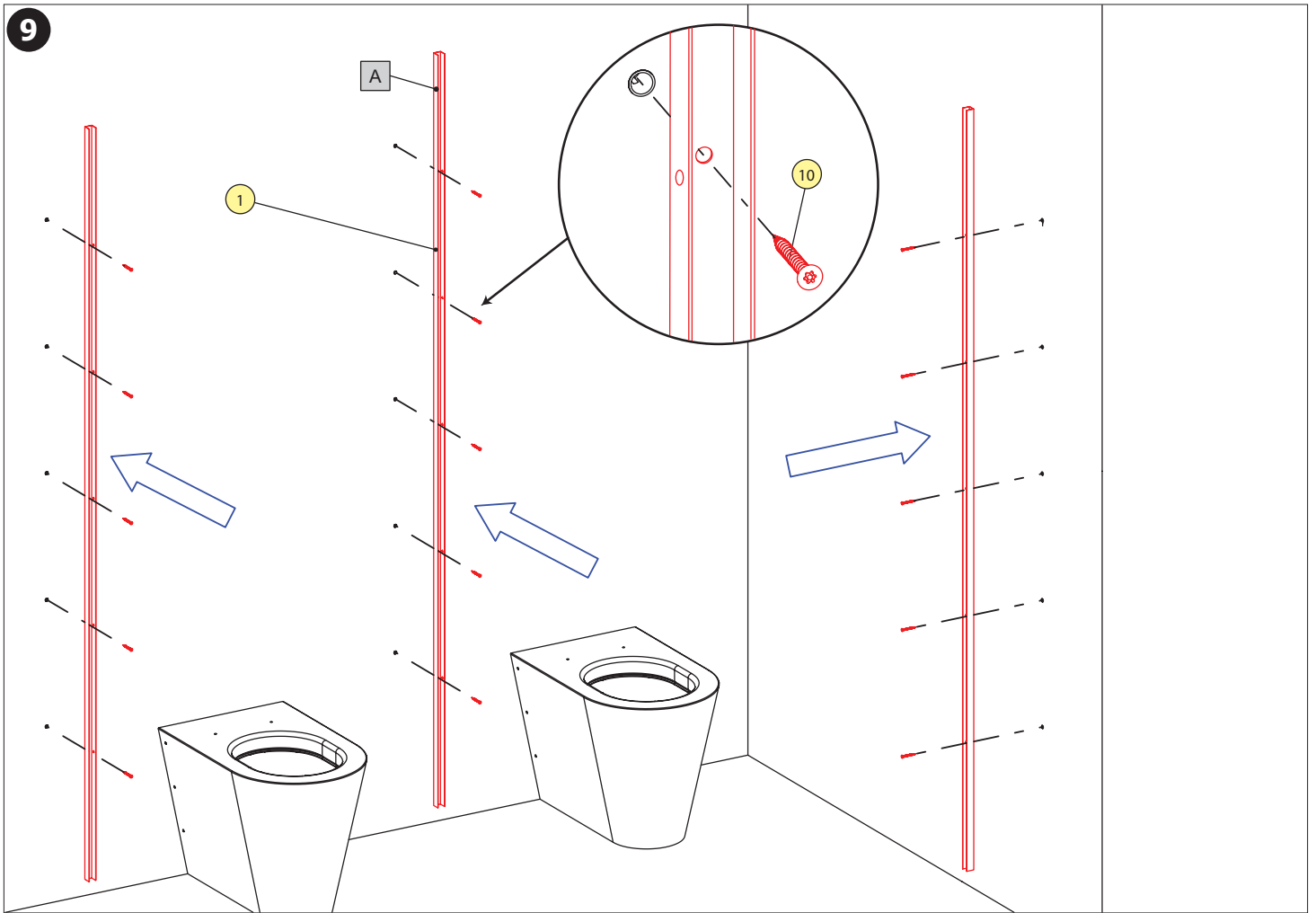

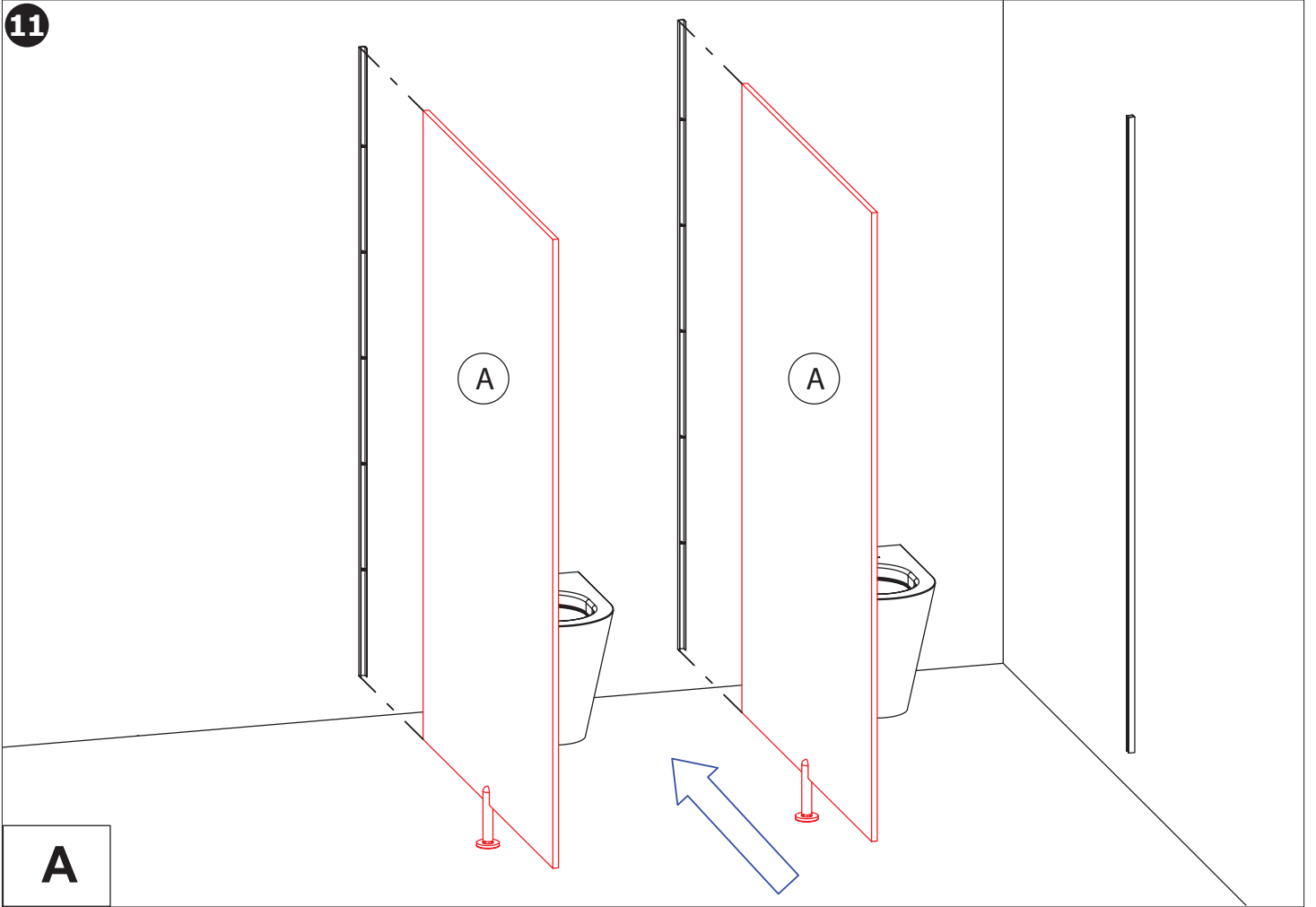

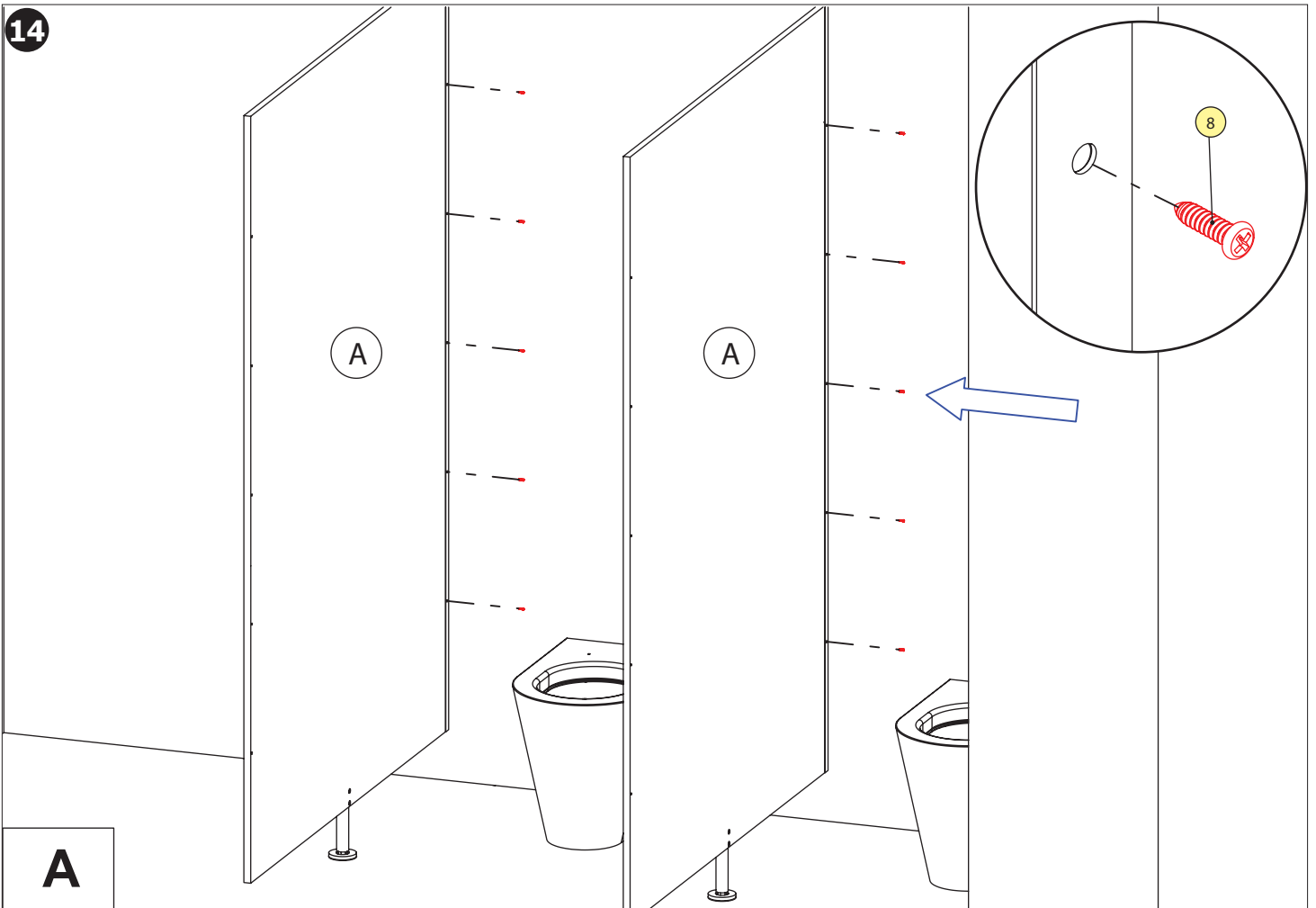
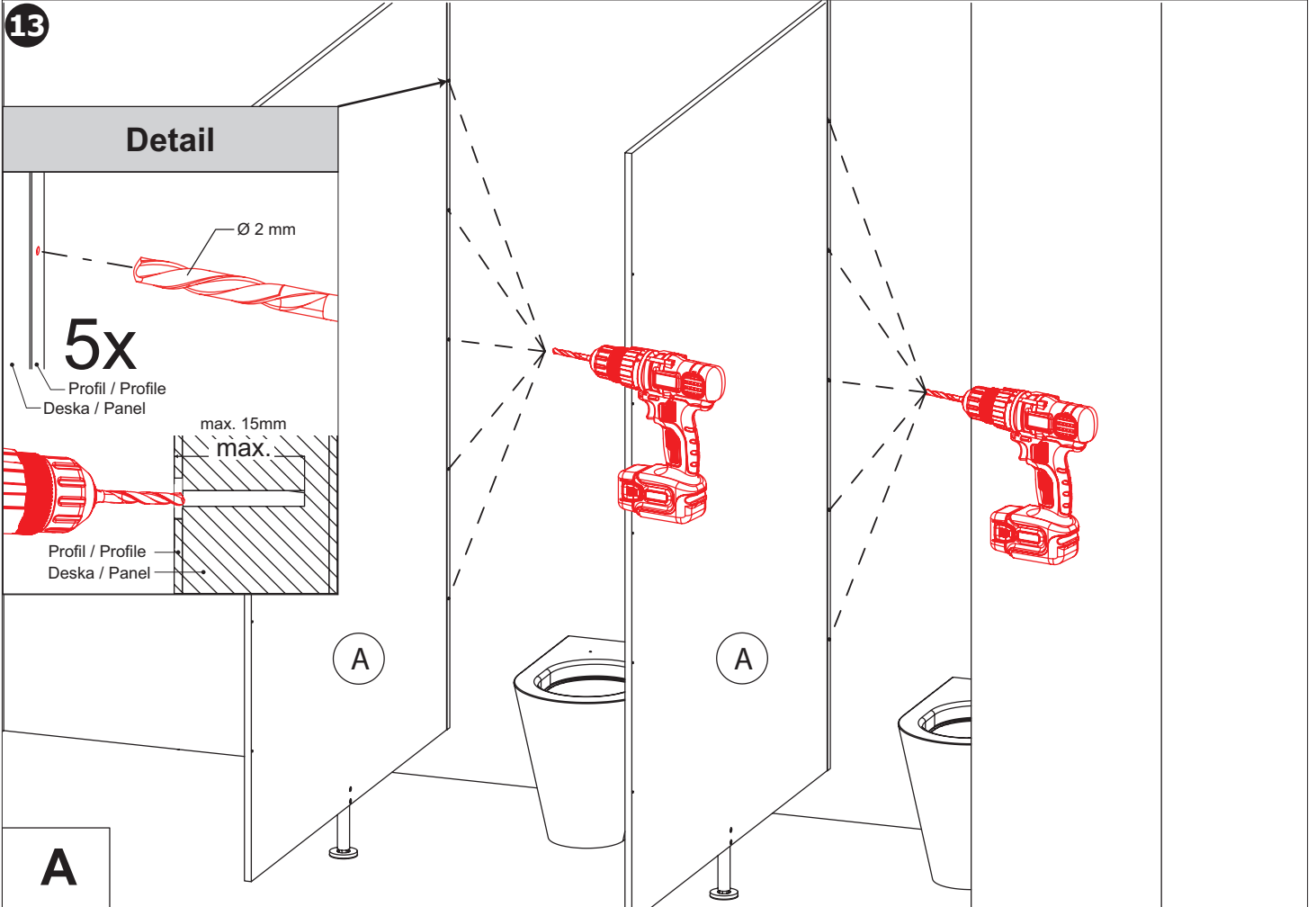

B

15

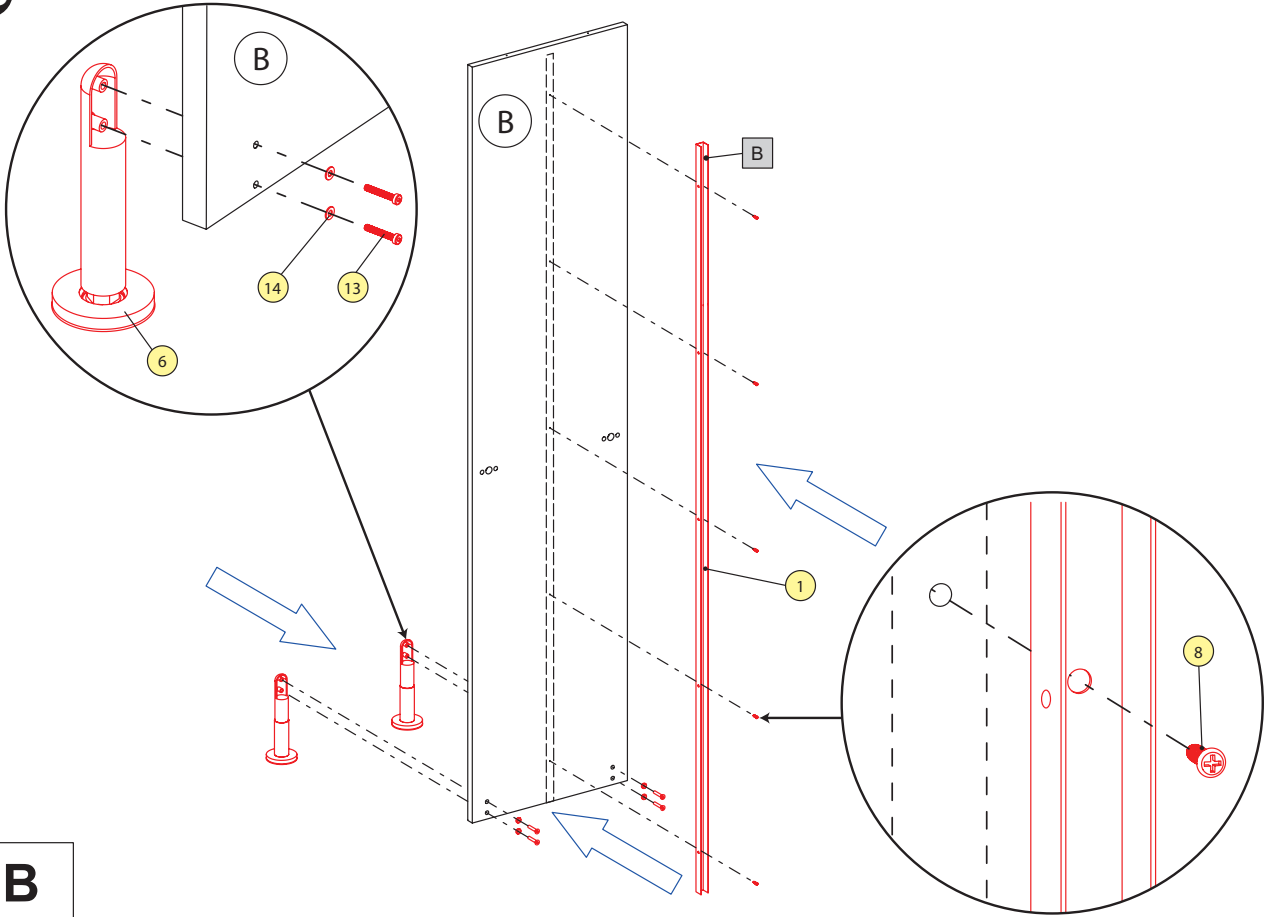

B

Detail

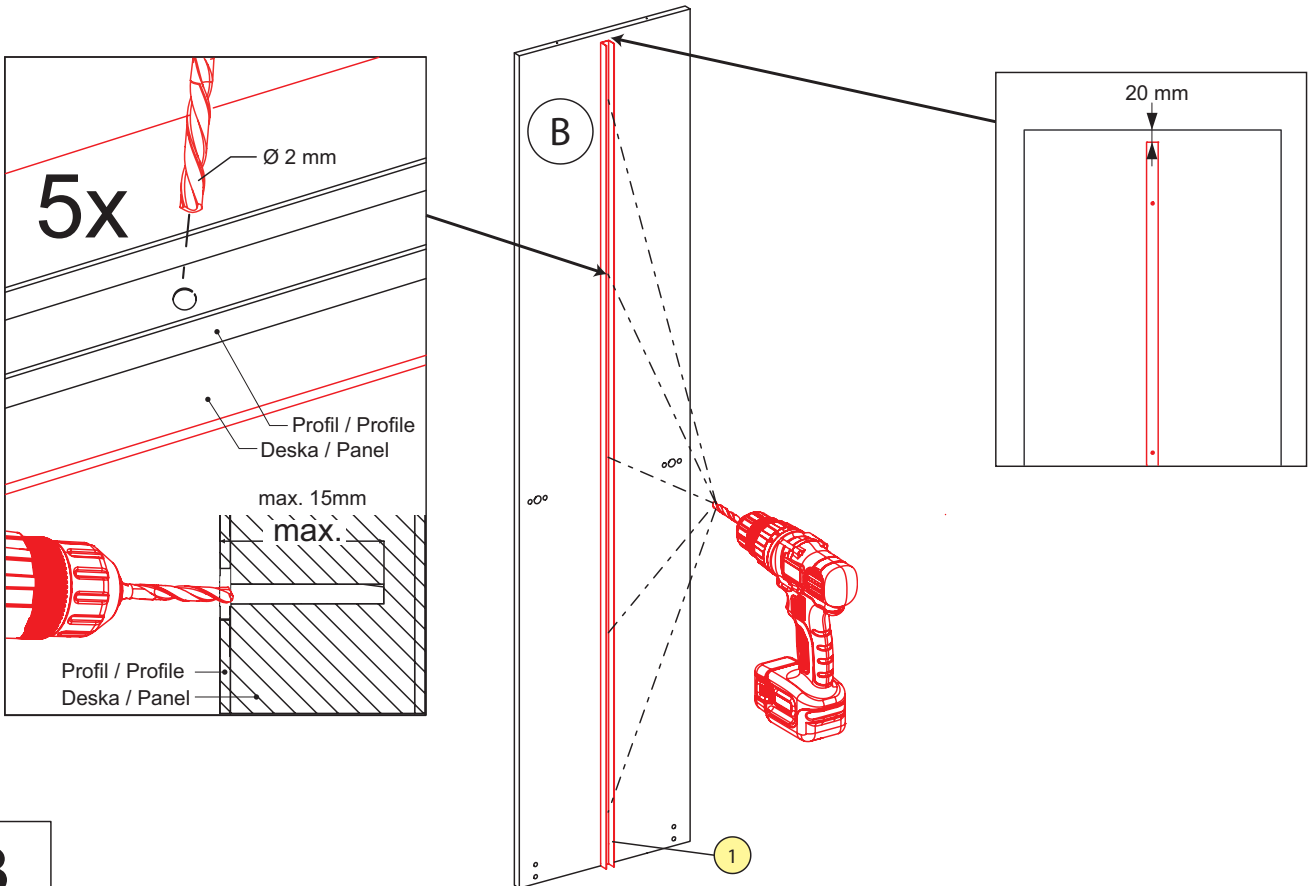

B

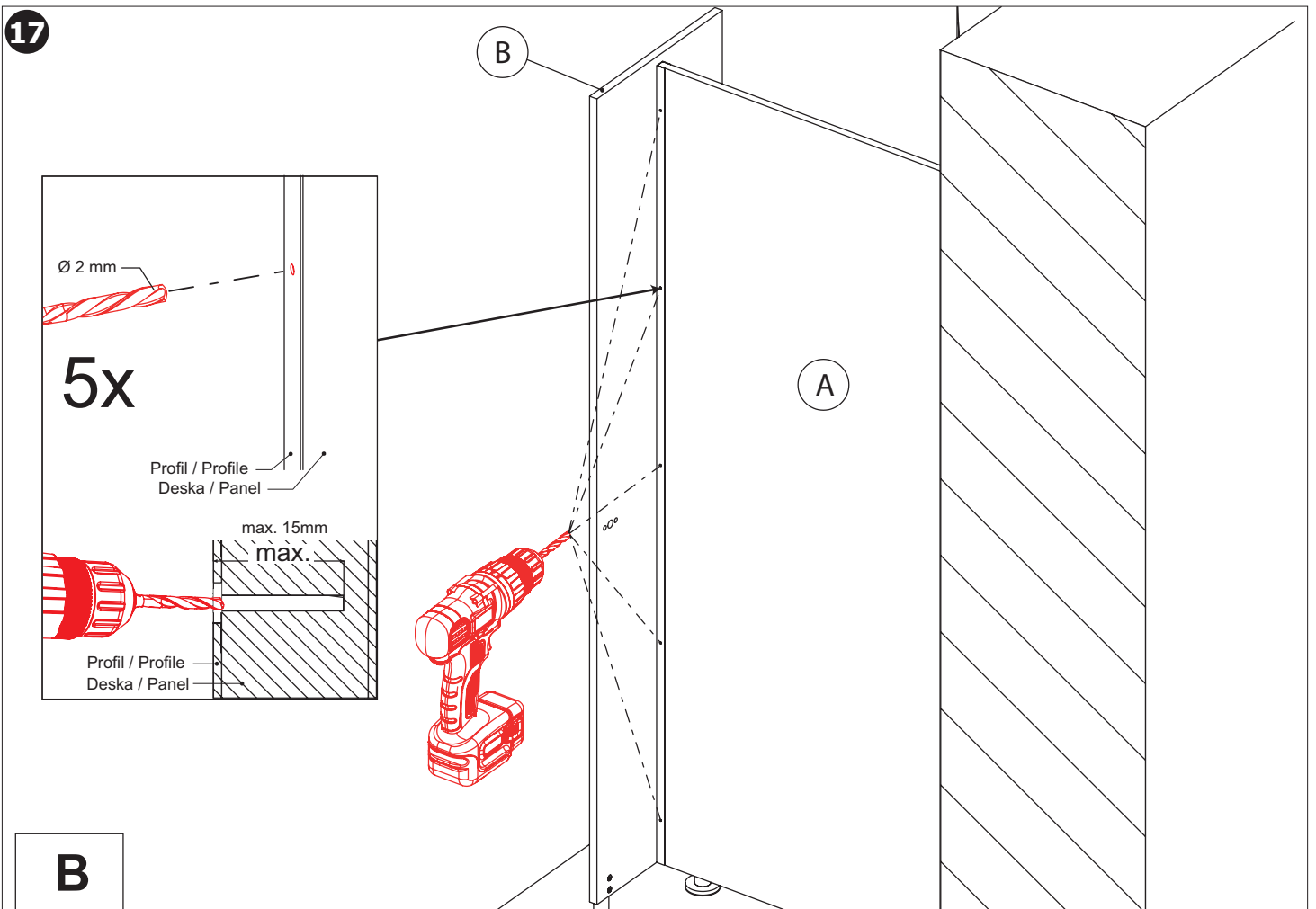
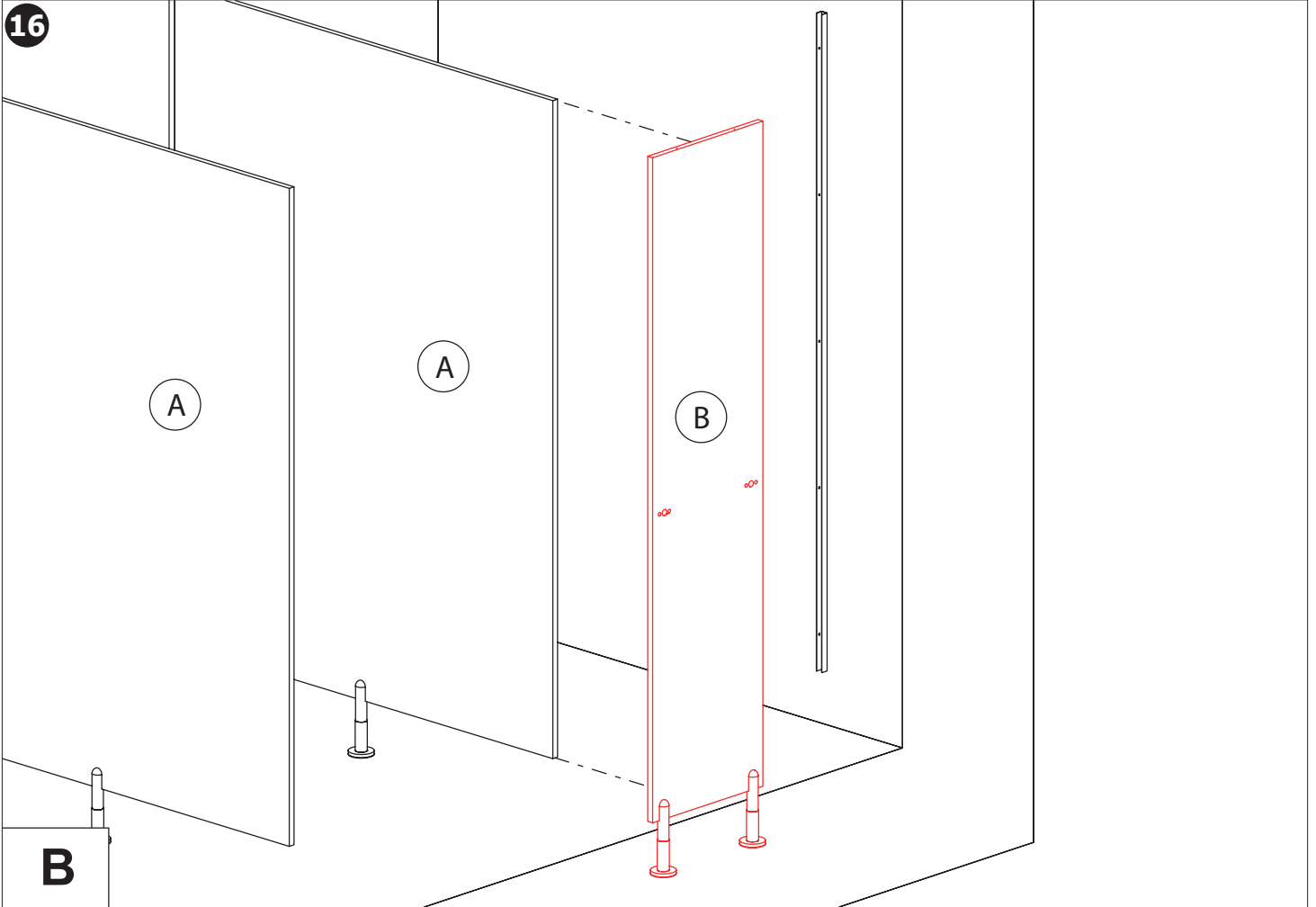

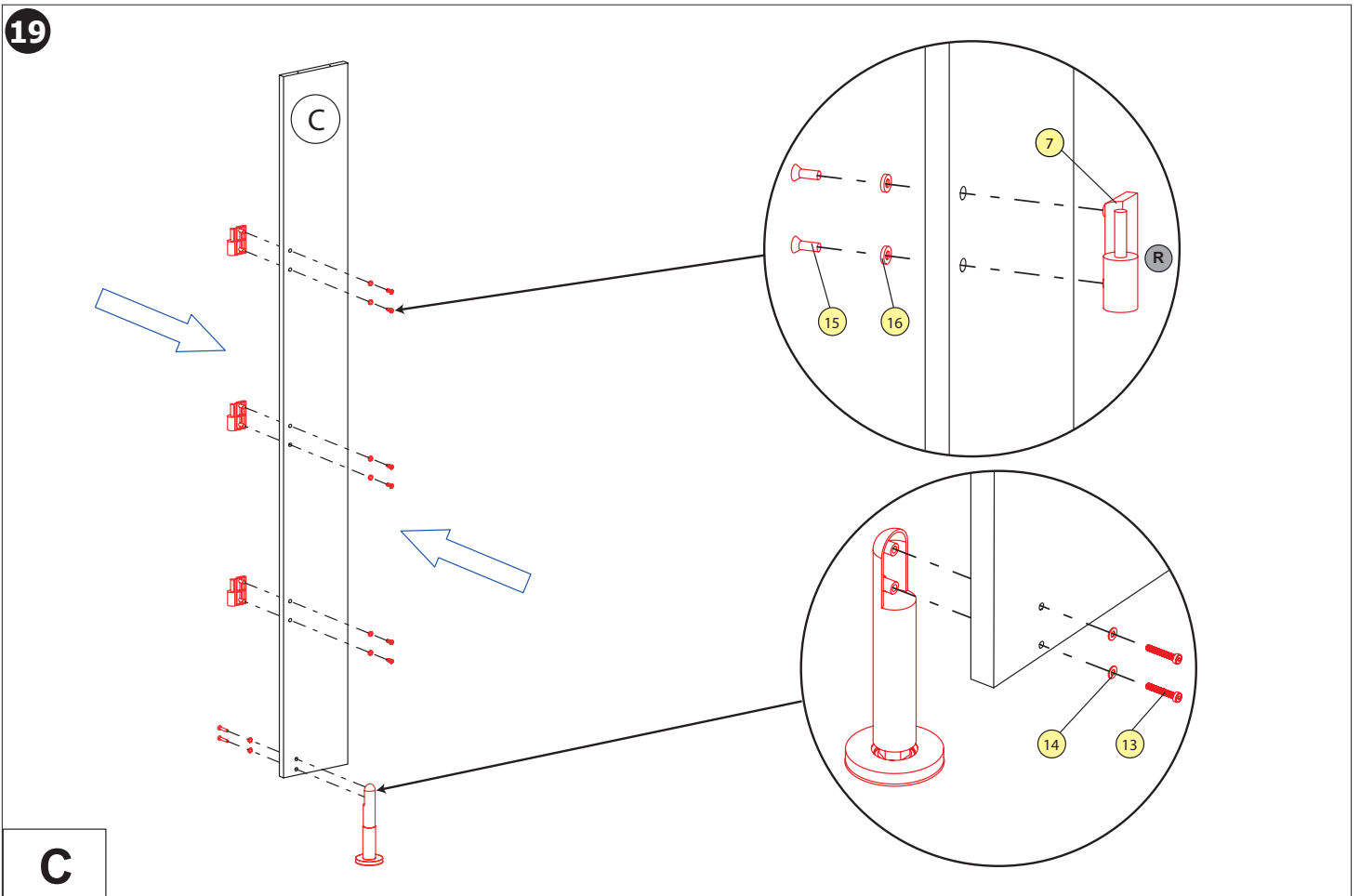
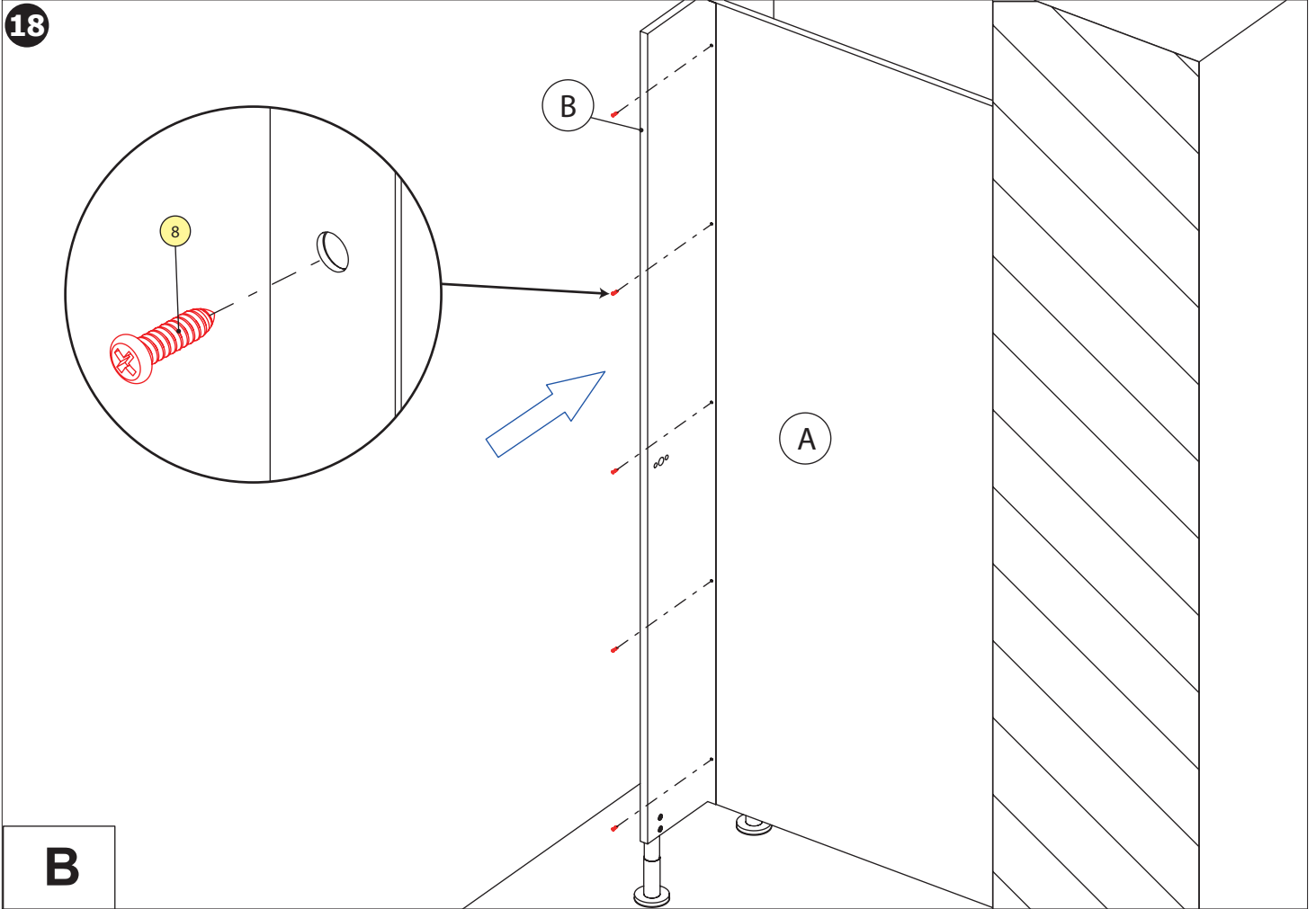

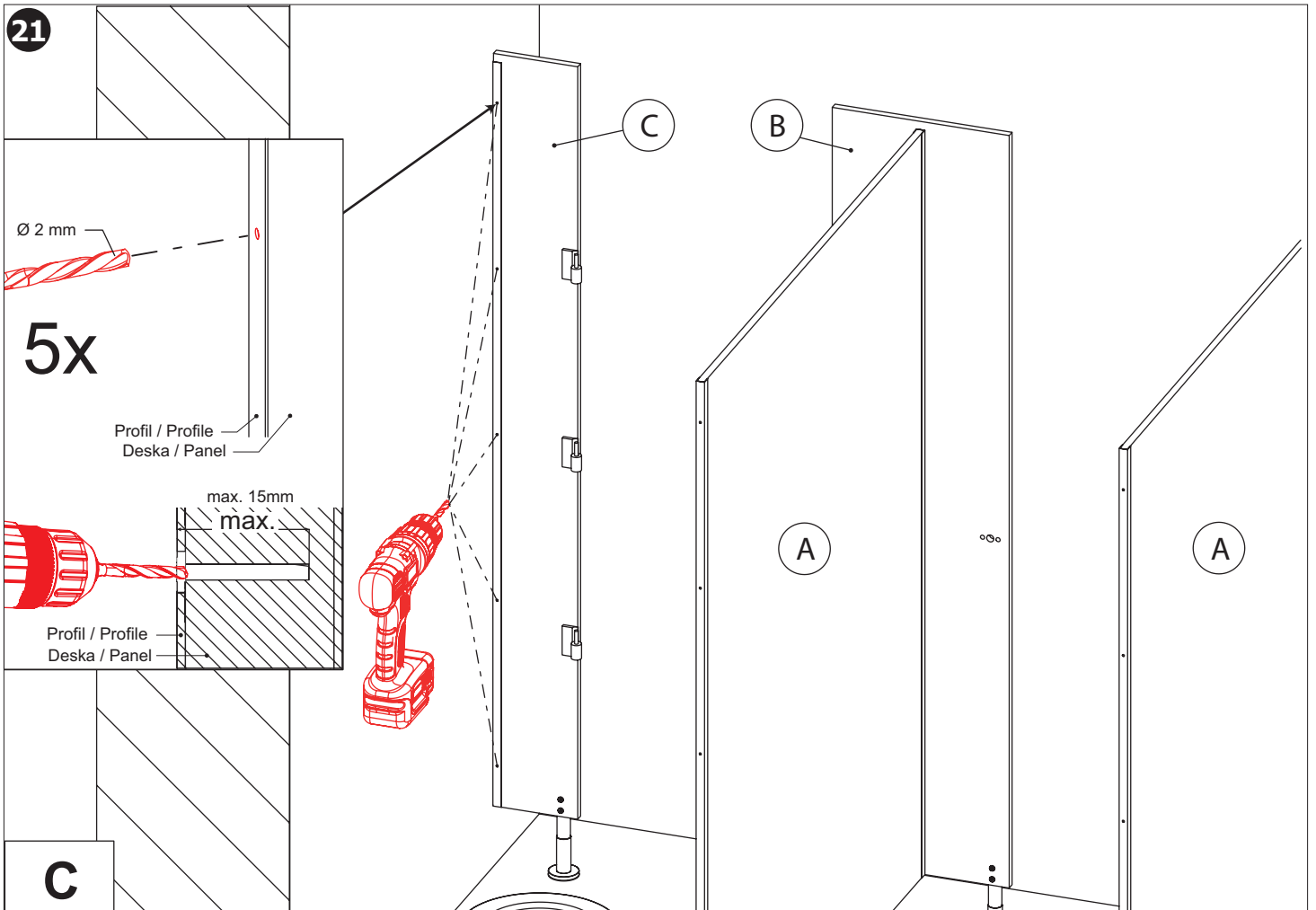
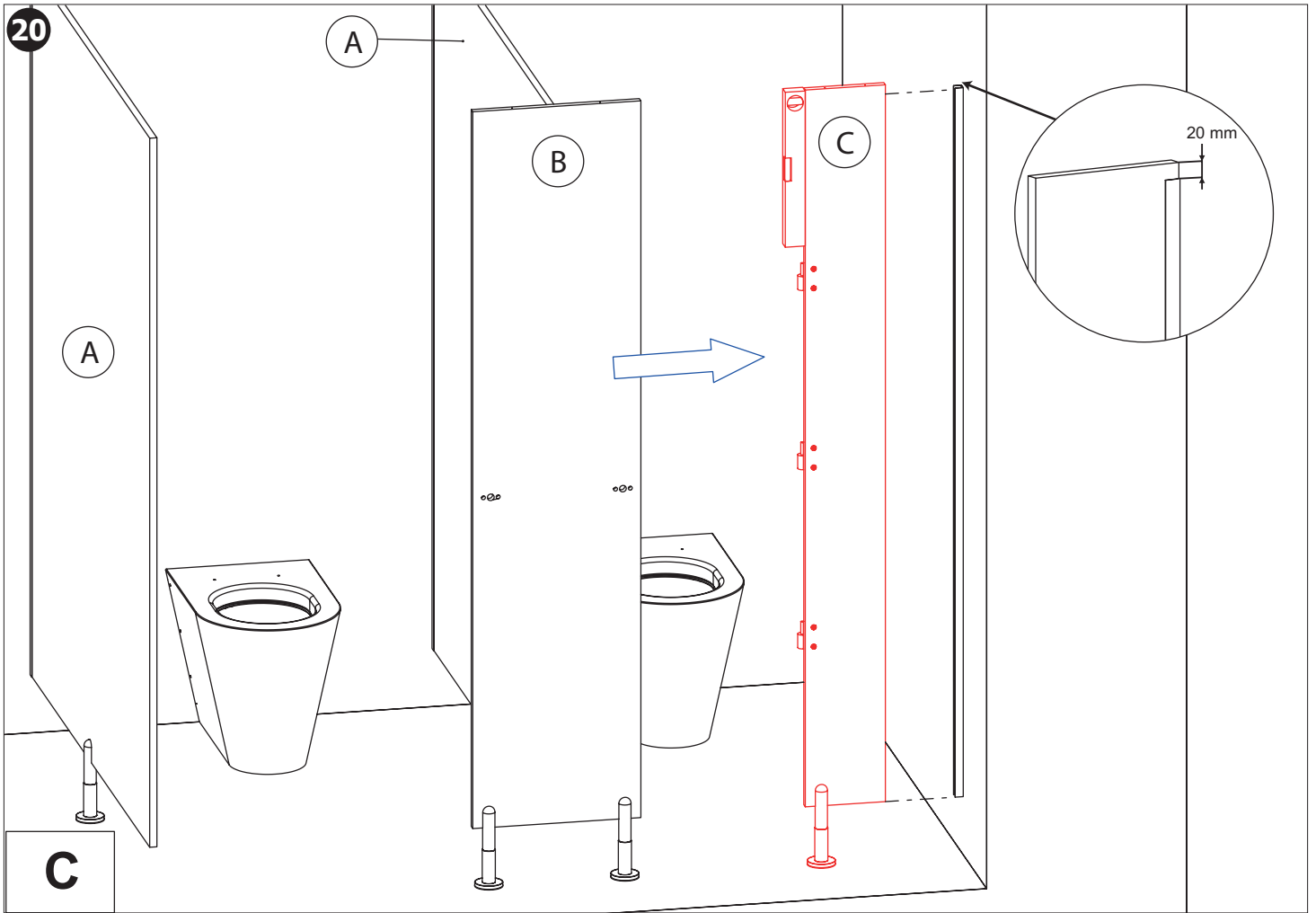

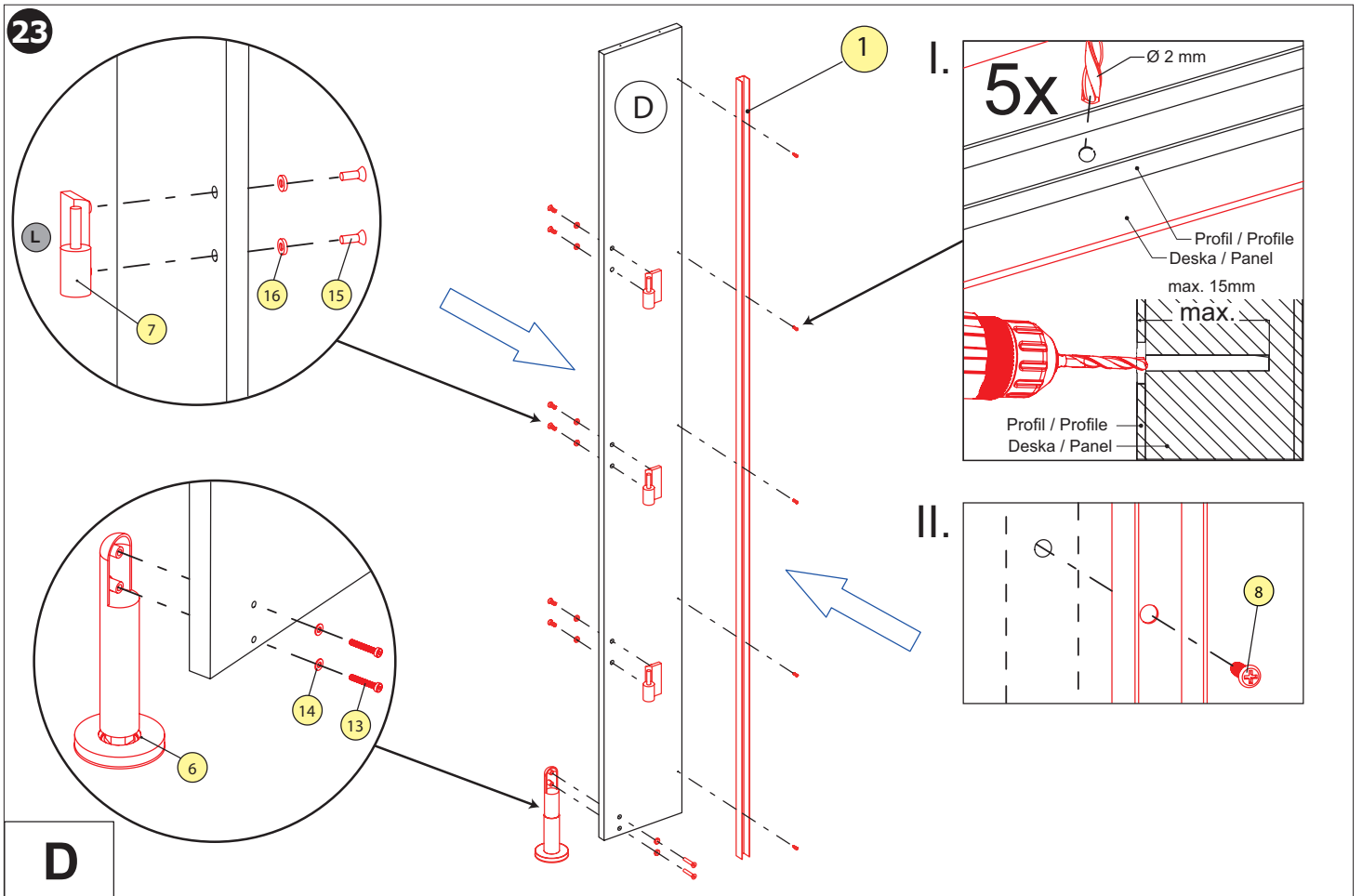
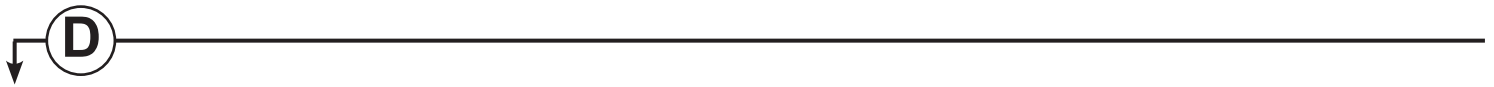
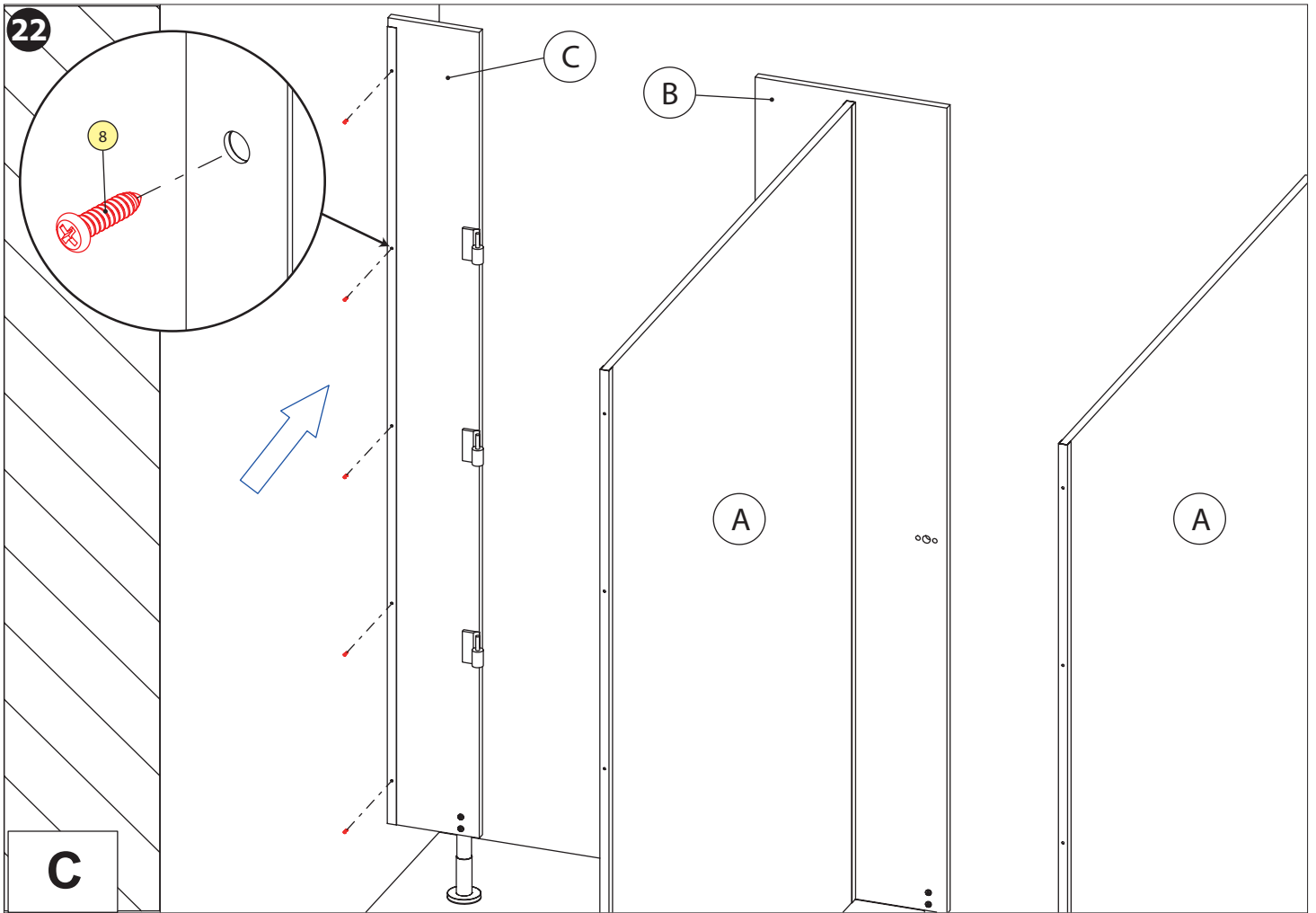

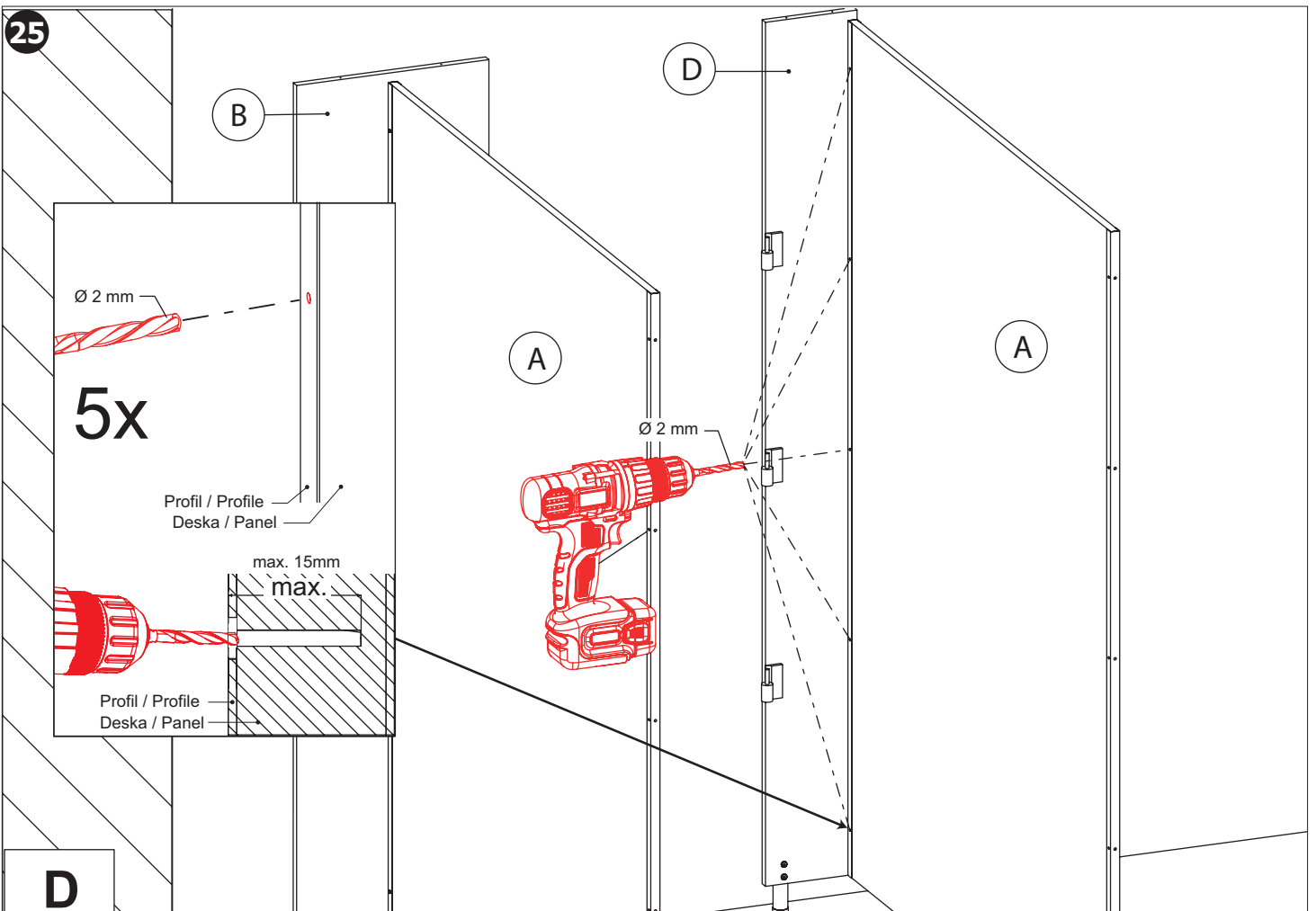
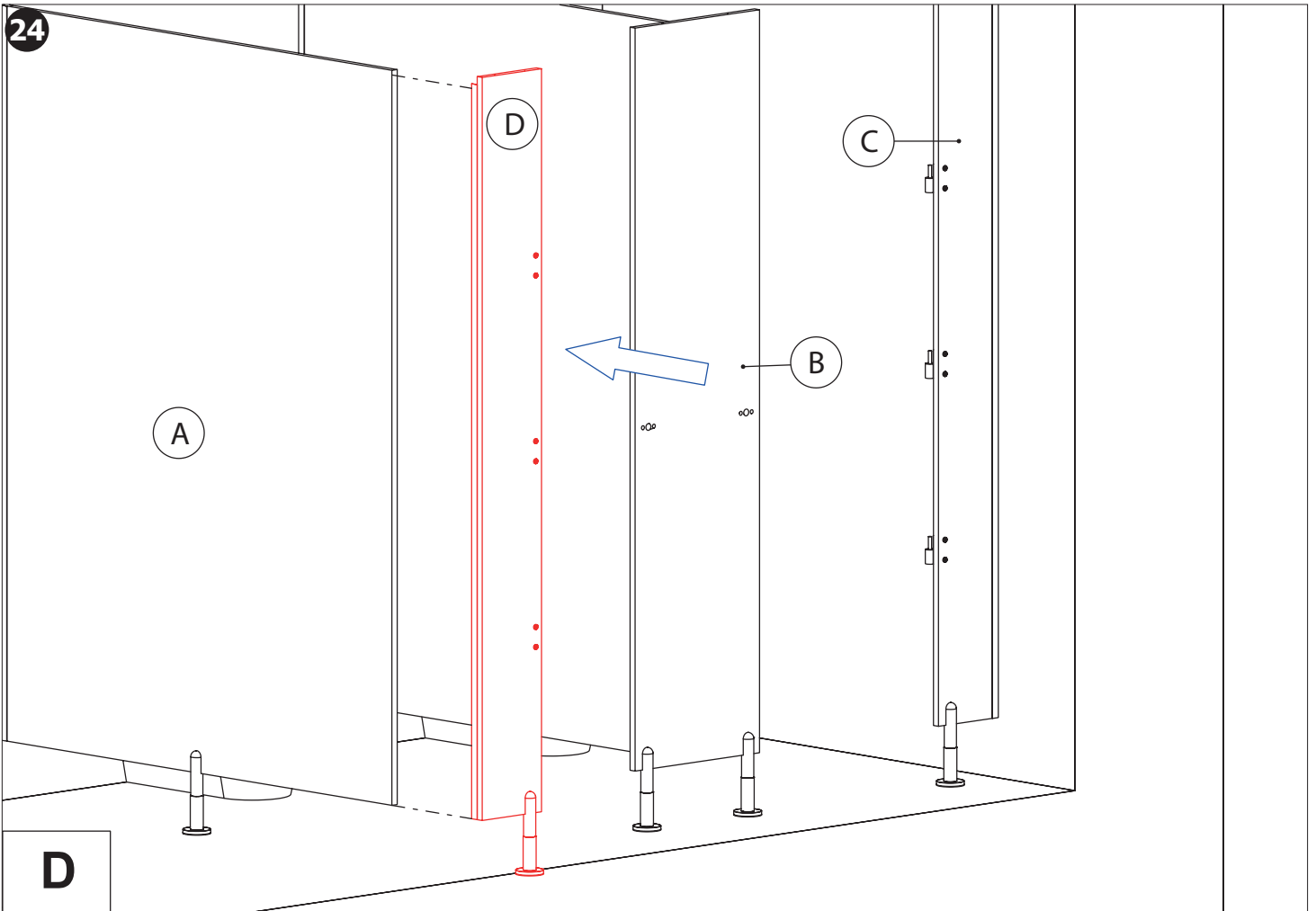

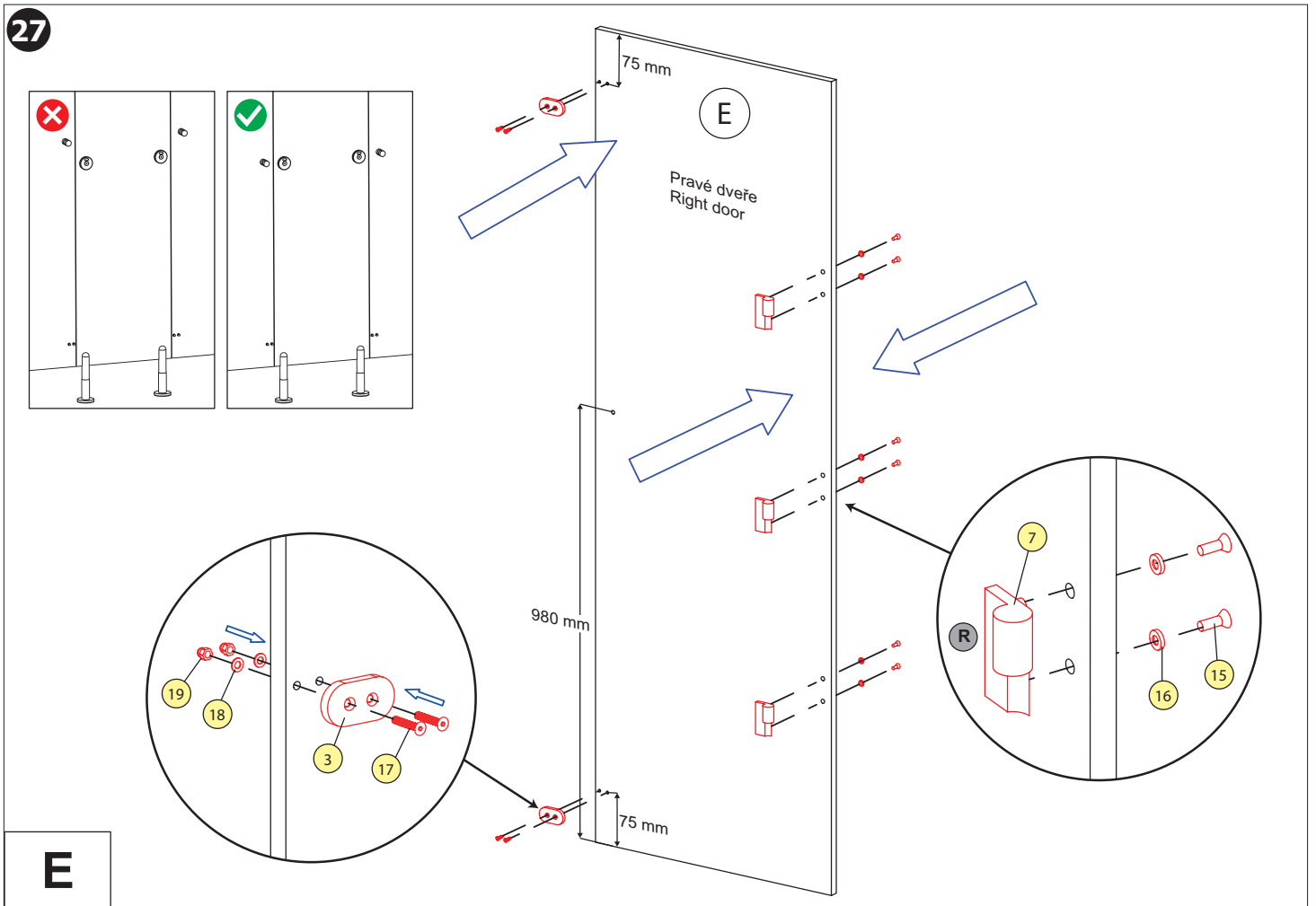
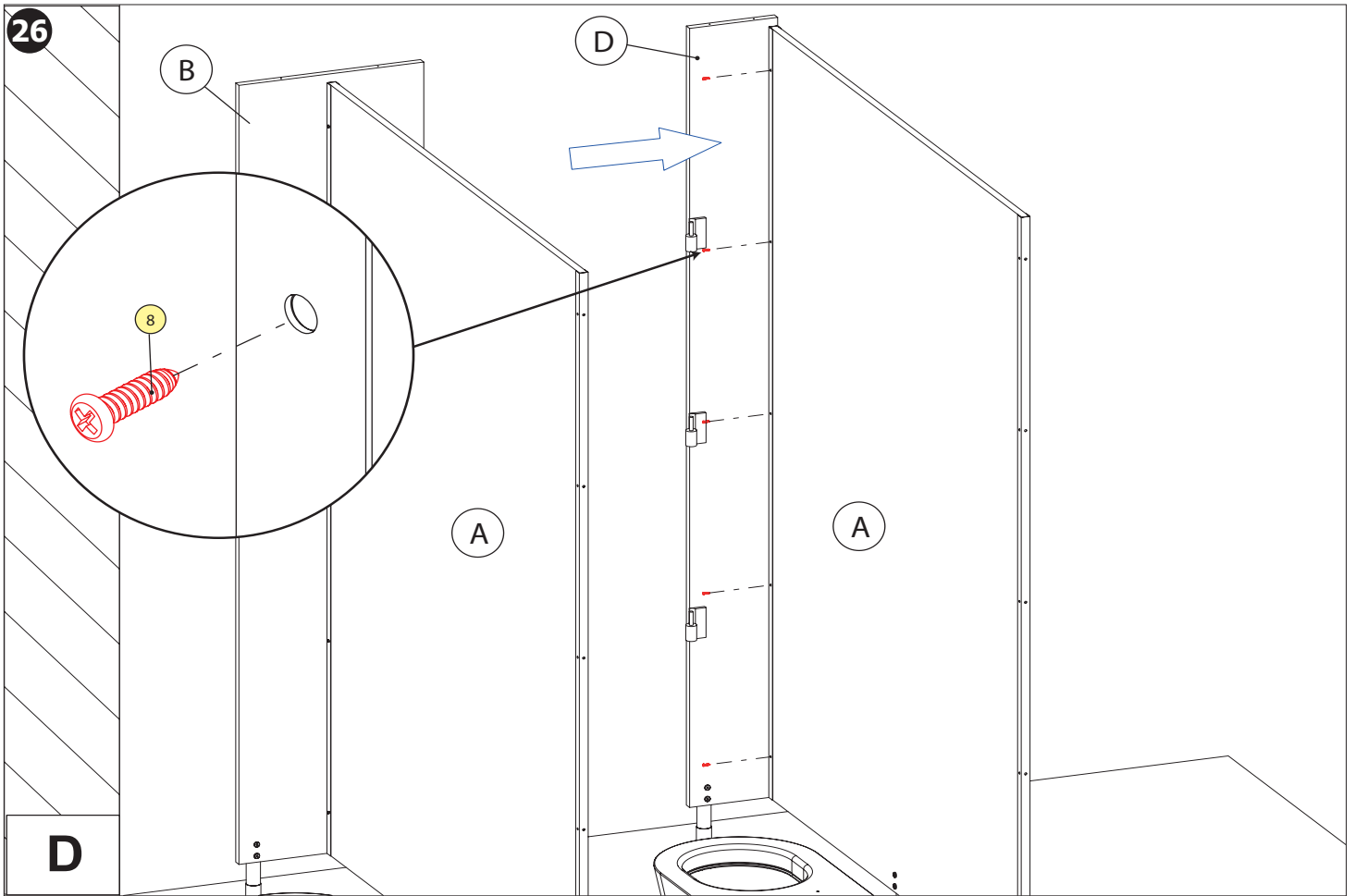

28

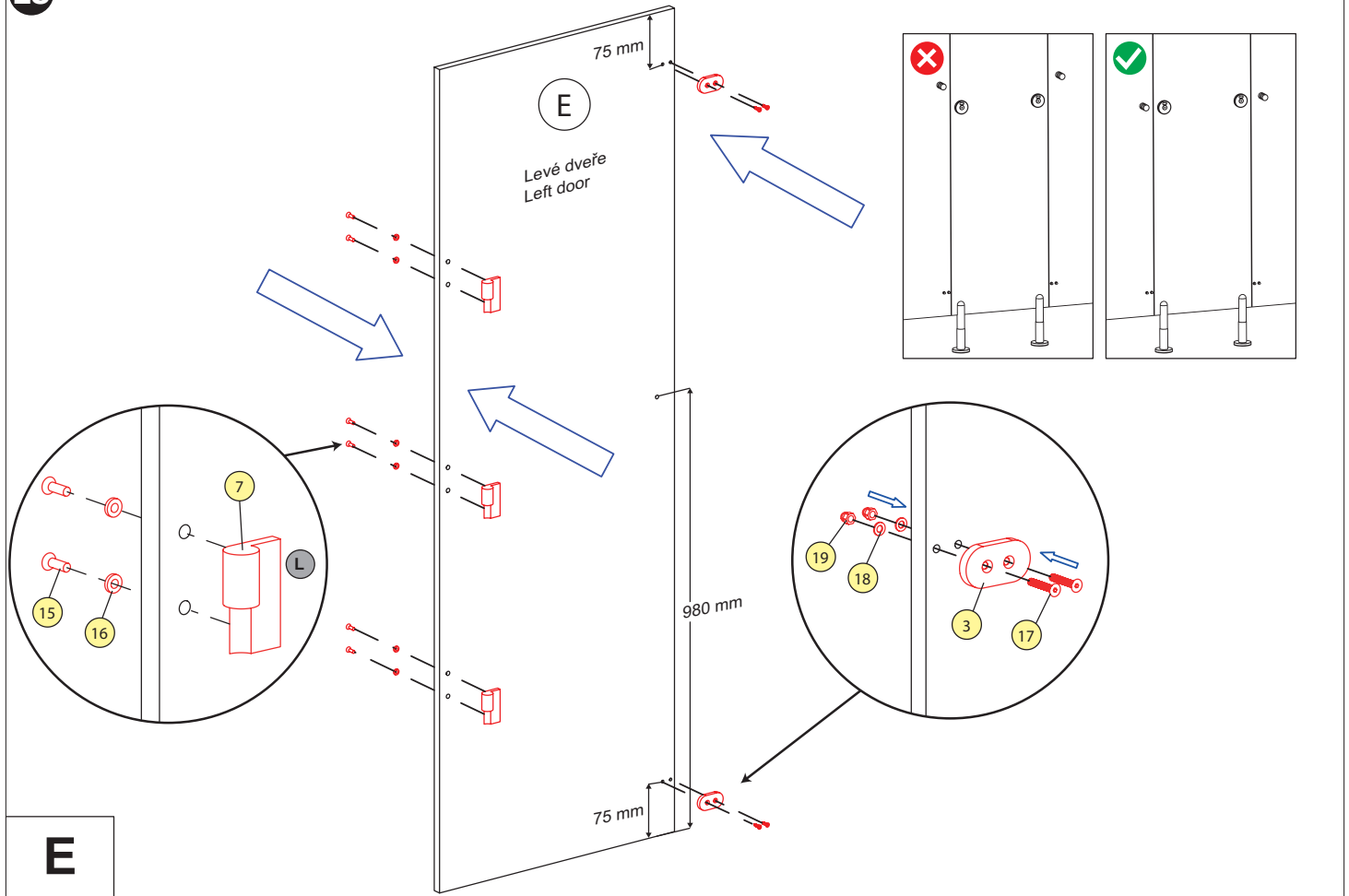

E

29

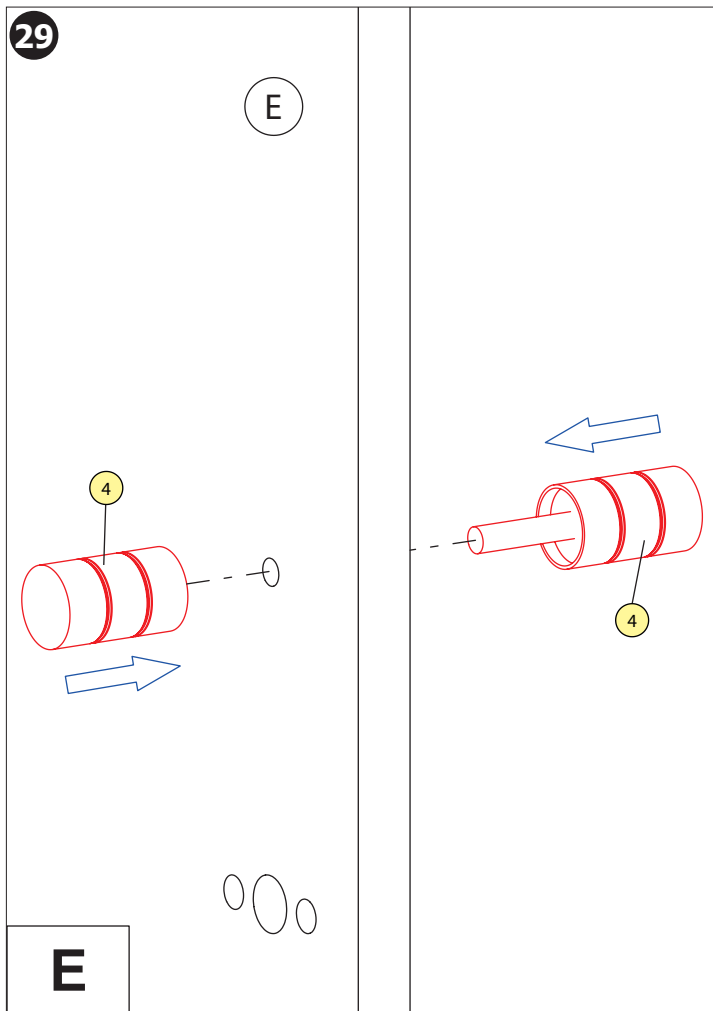

30

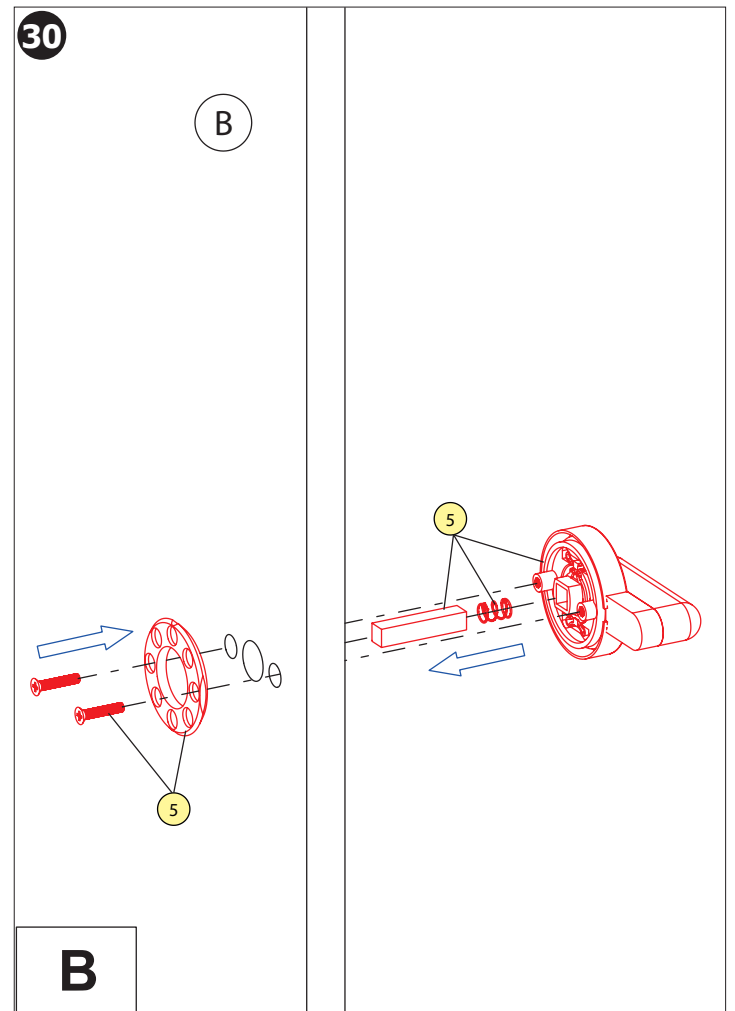

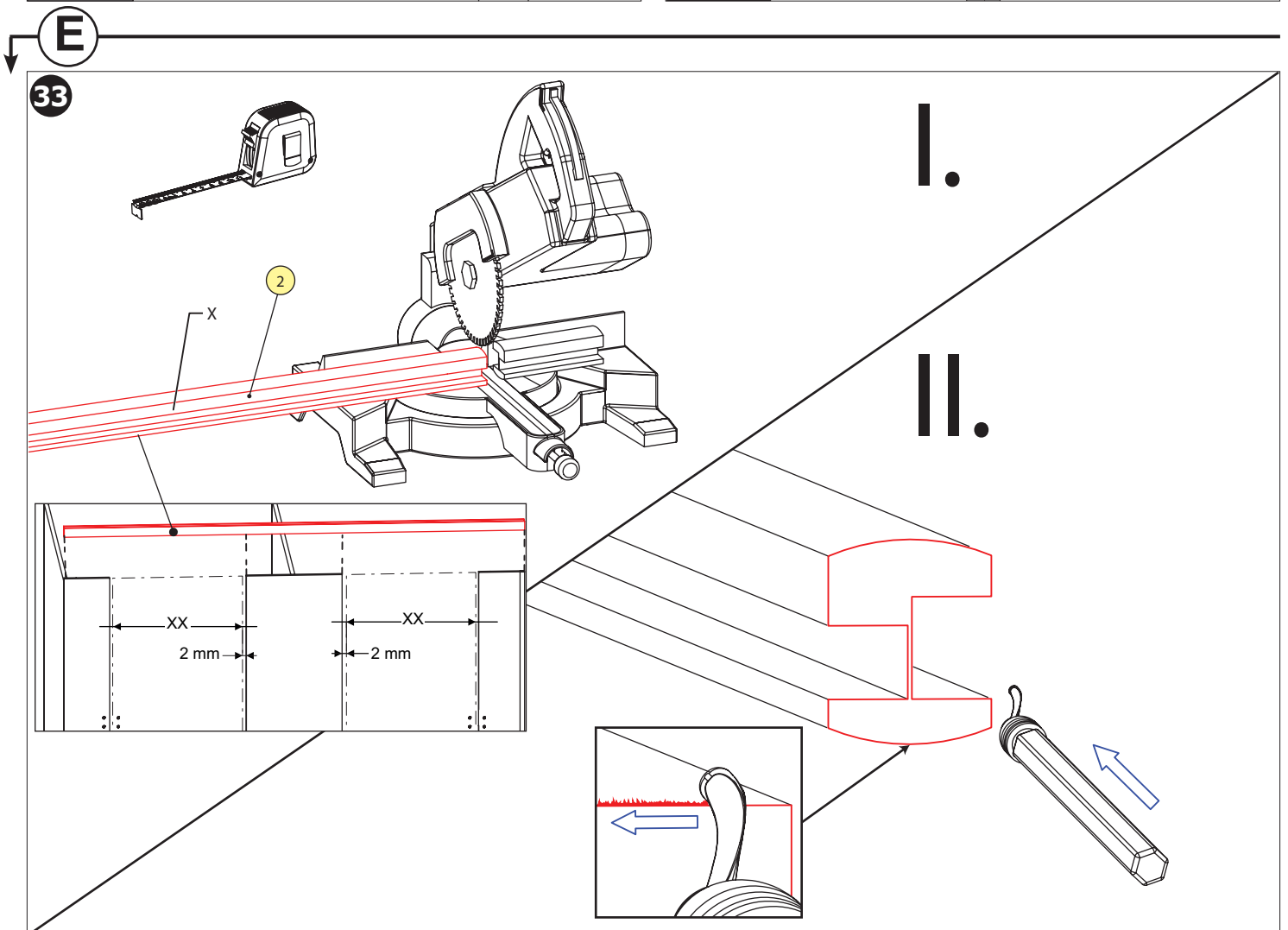
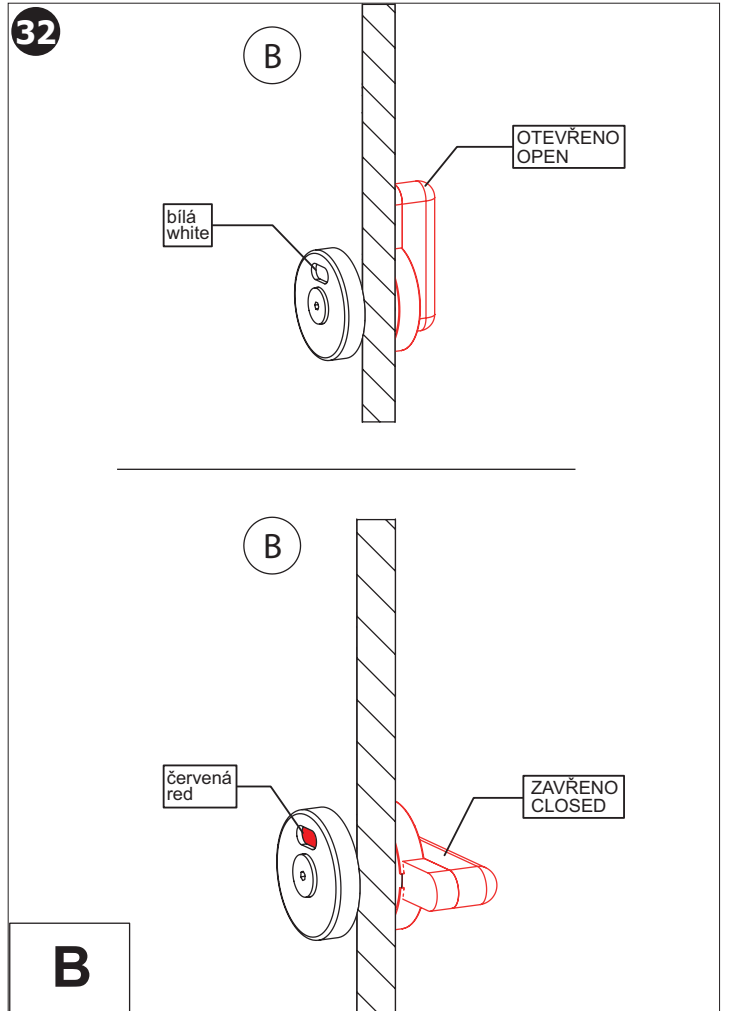
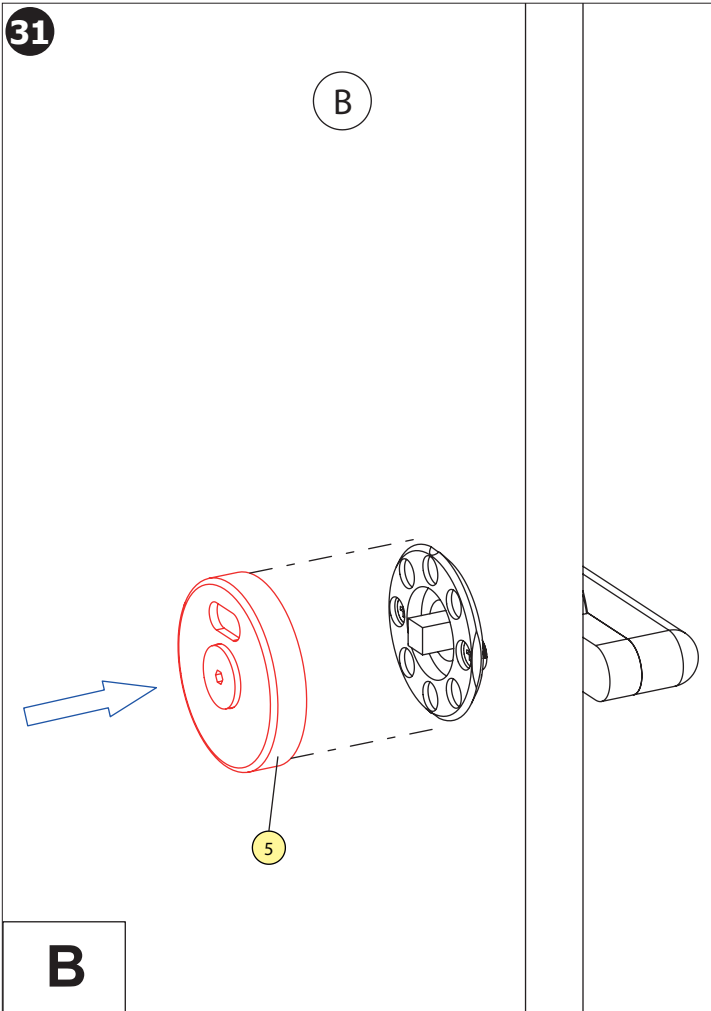

34

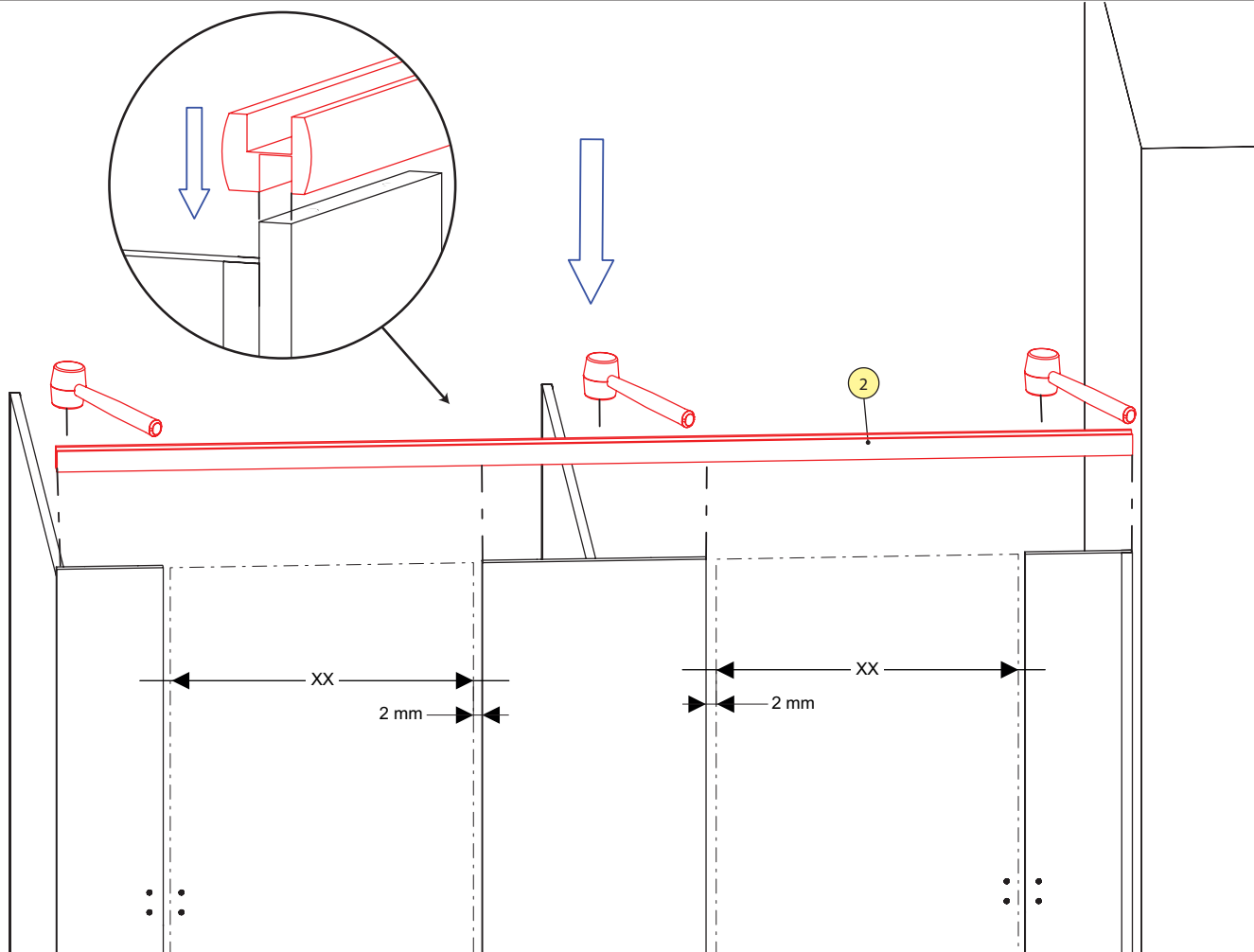

35

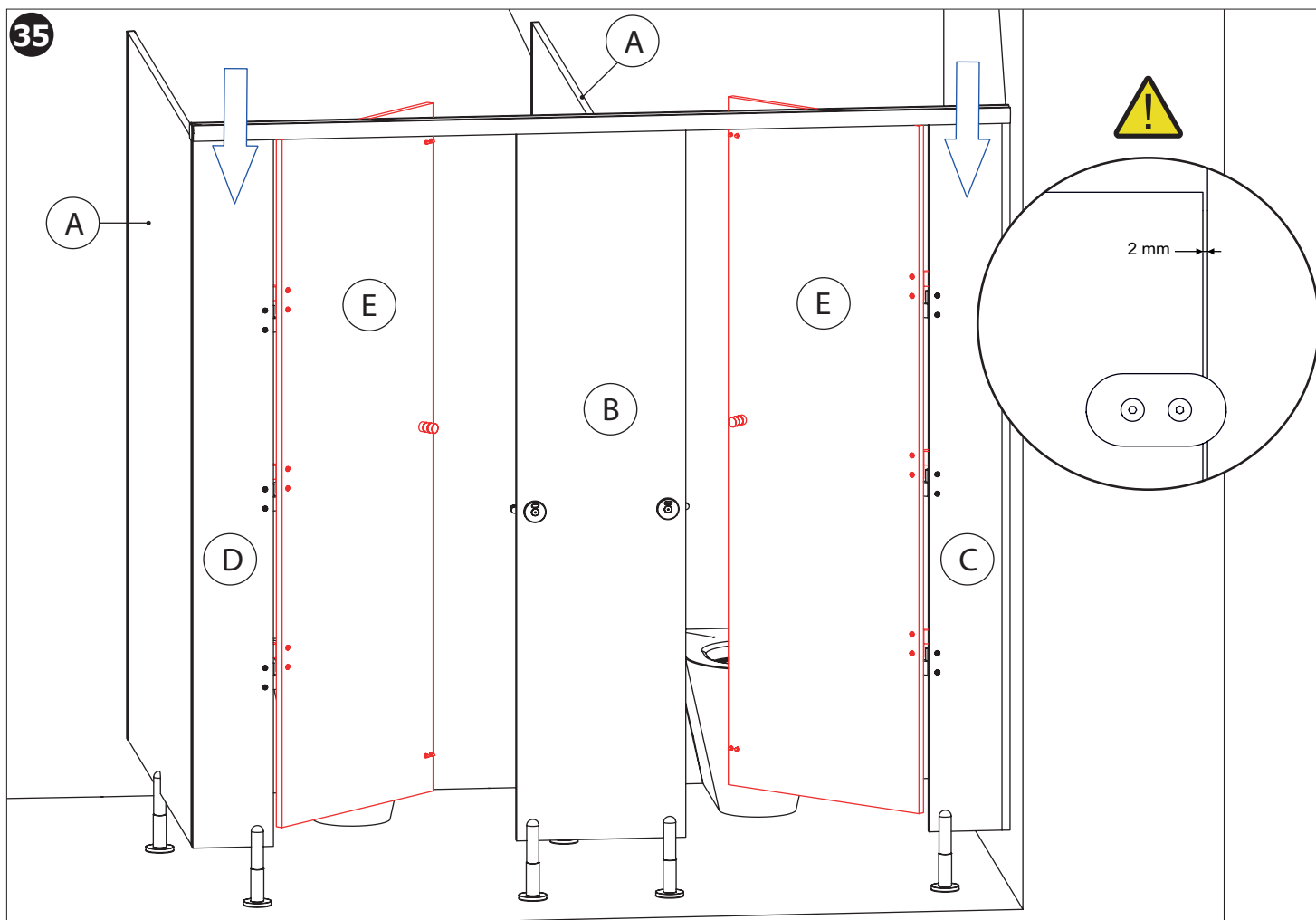

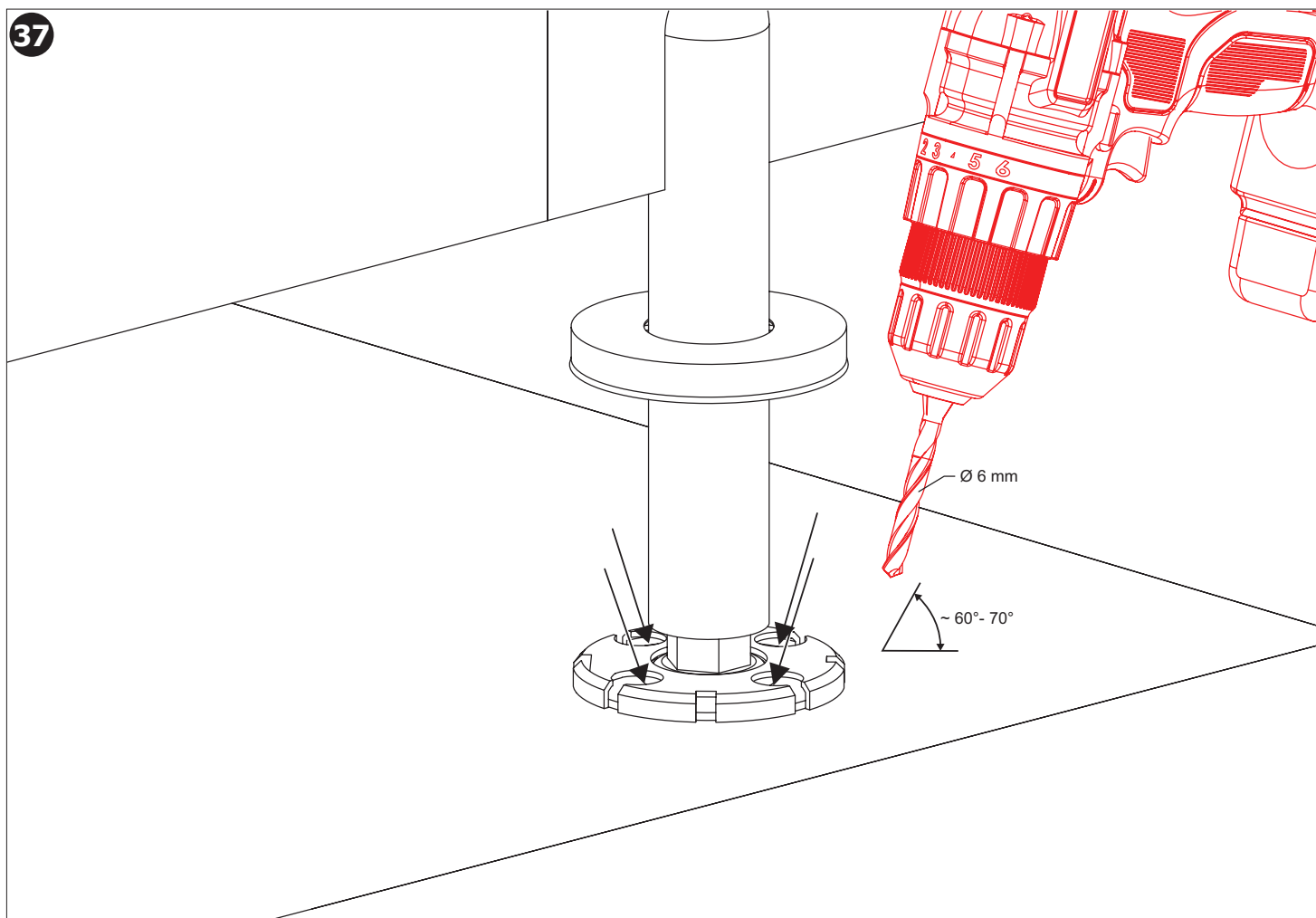
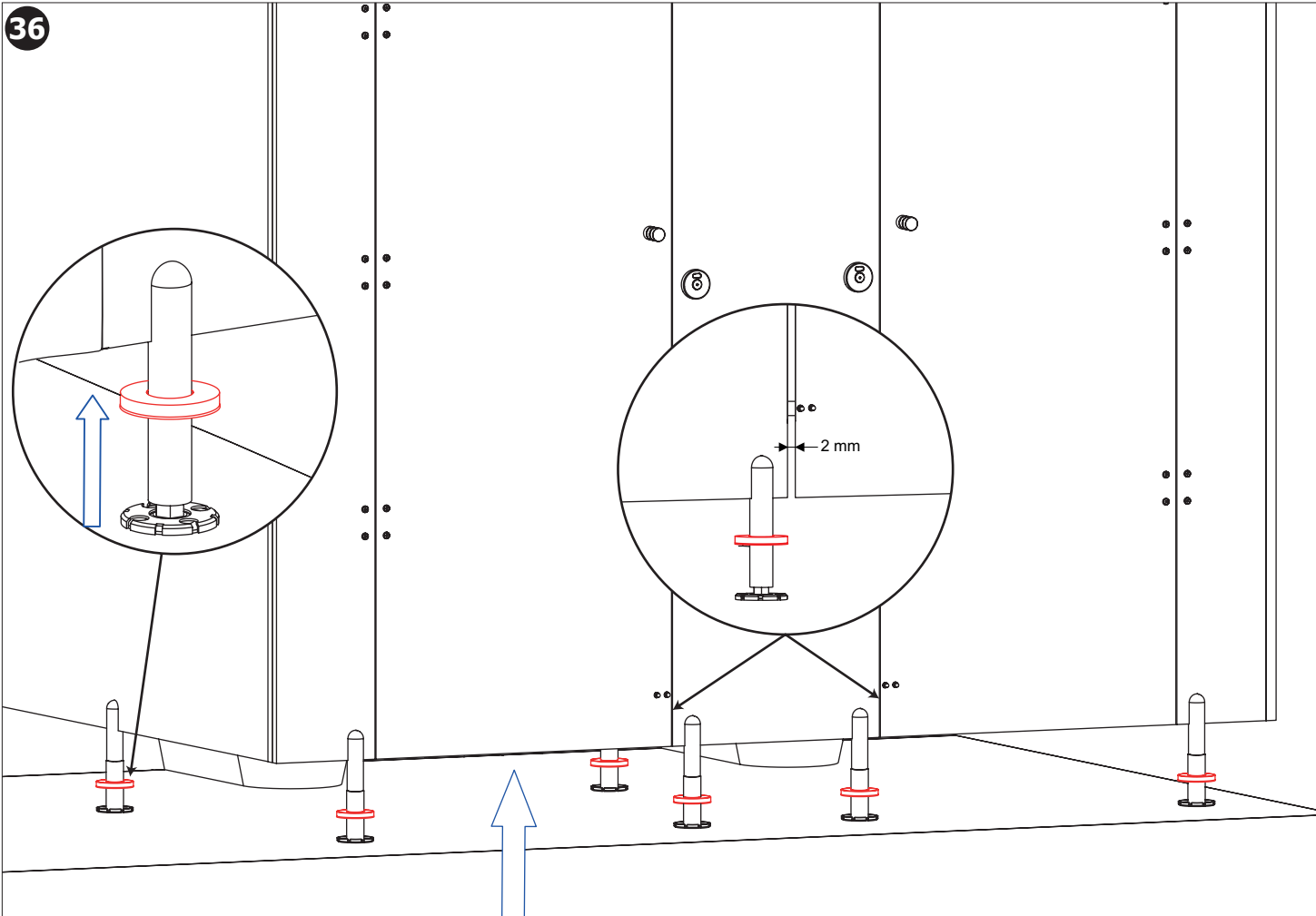

38

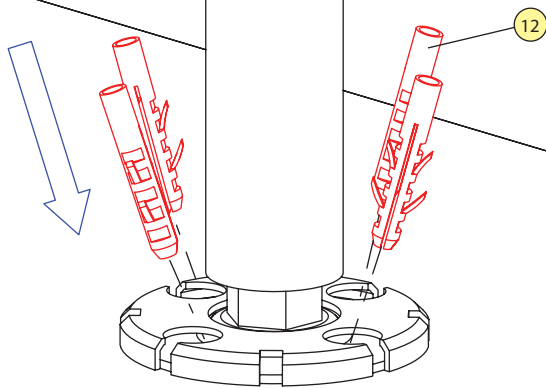

39

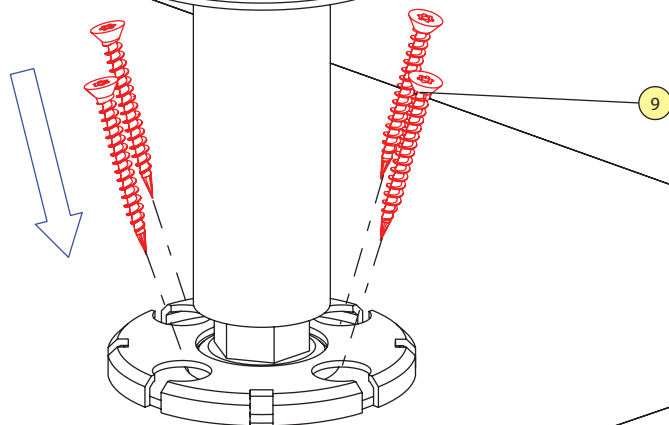

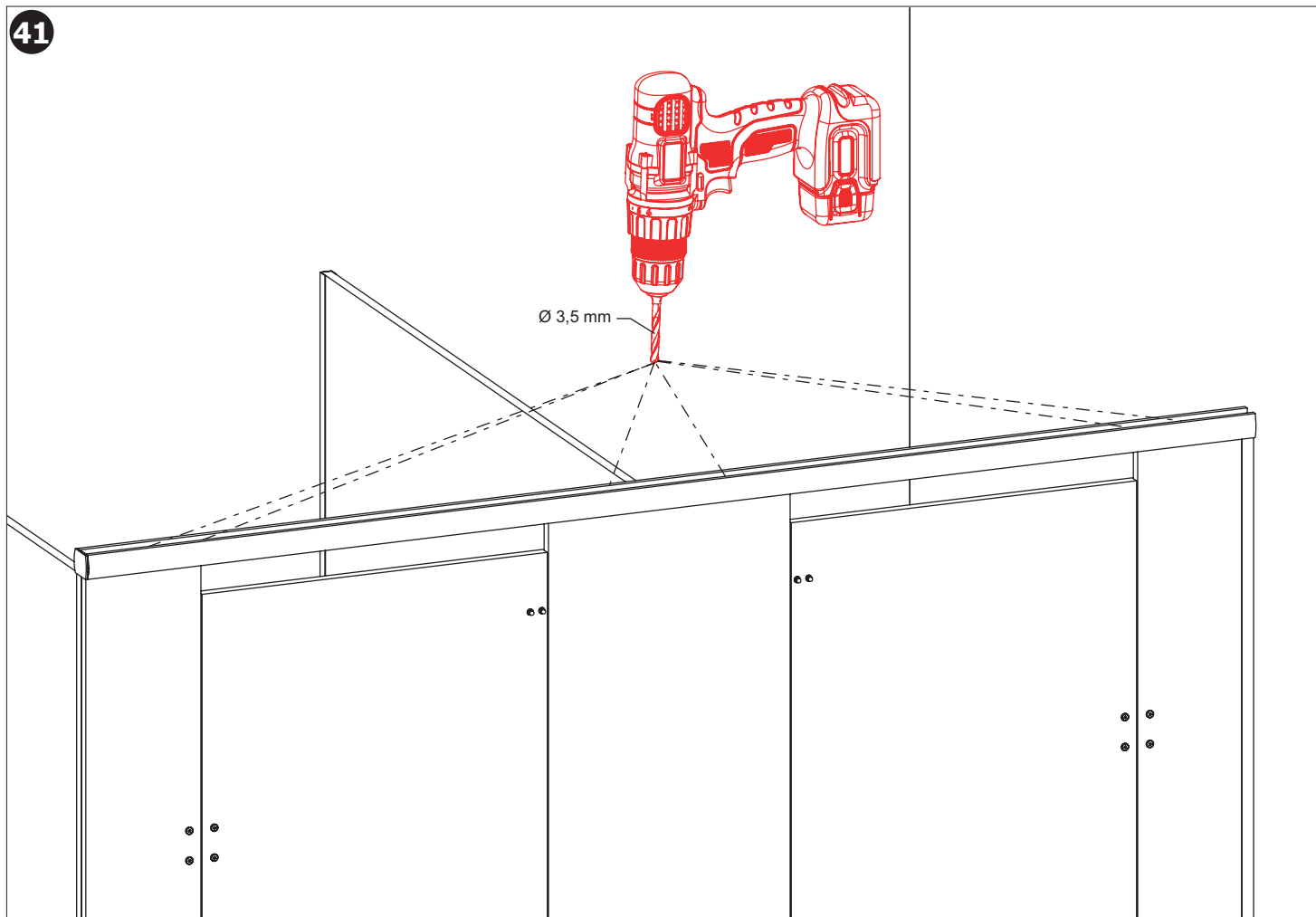
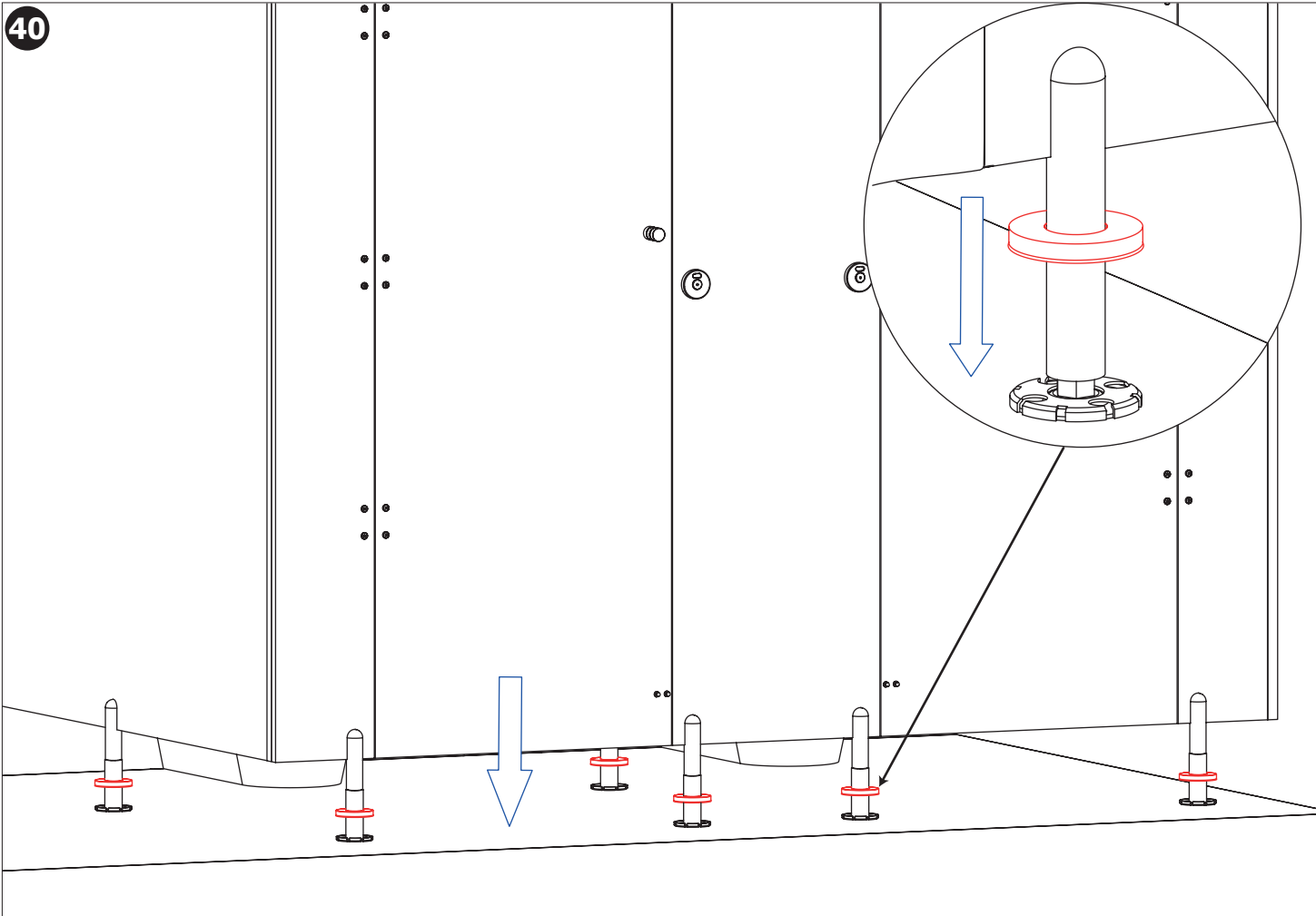

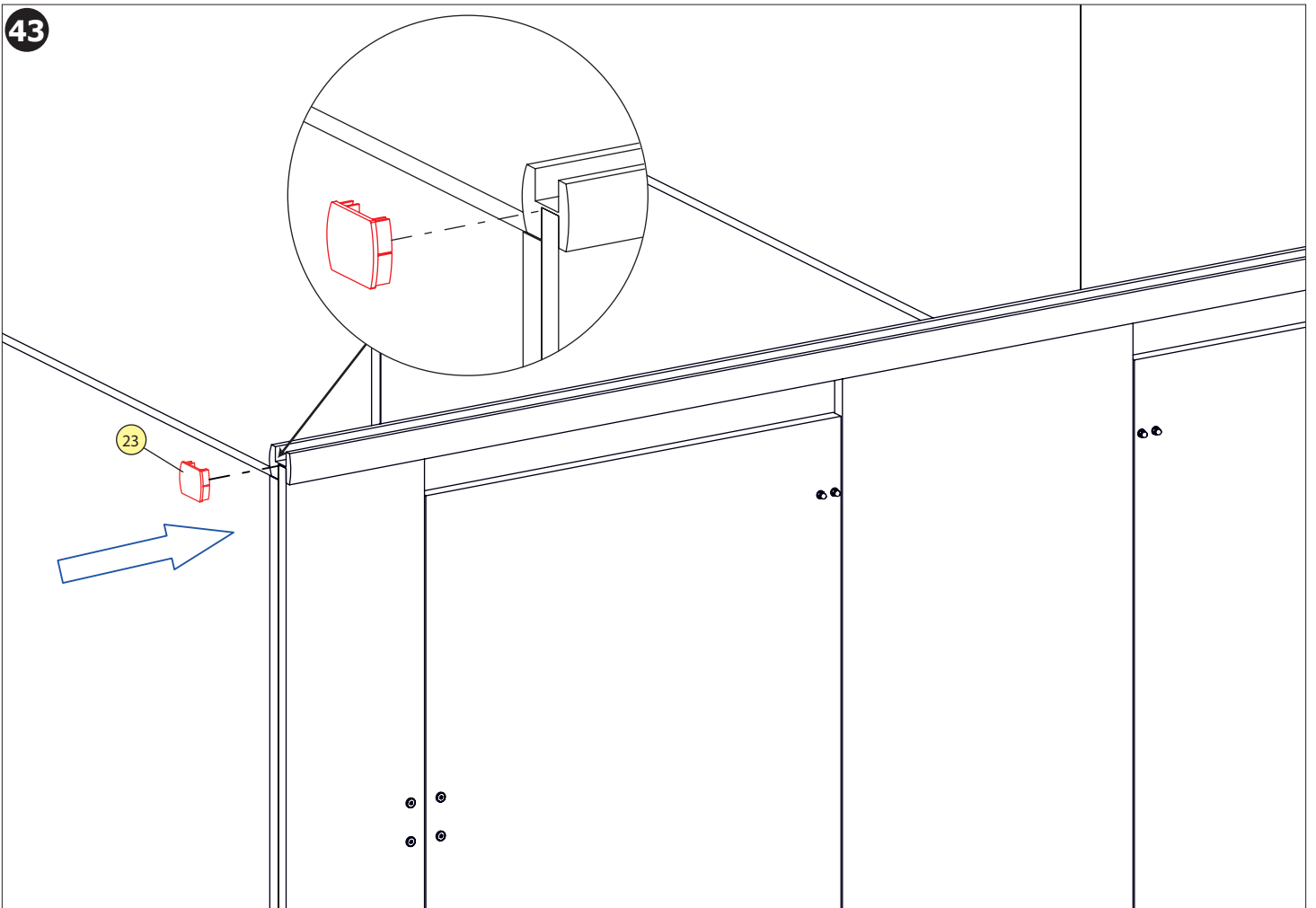
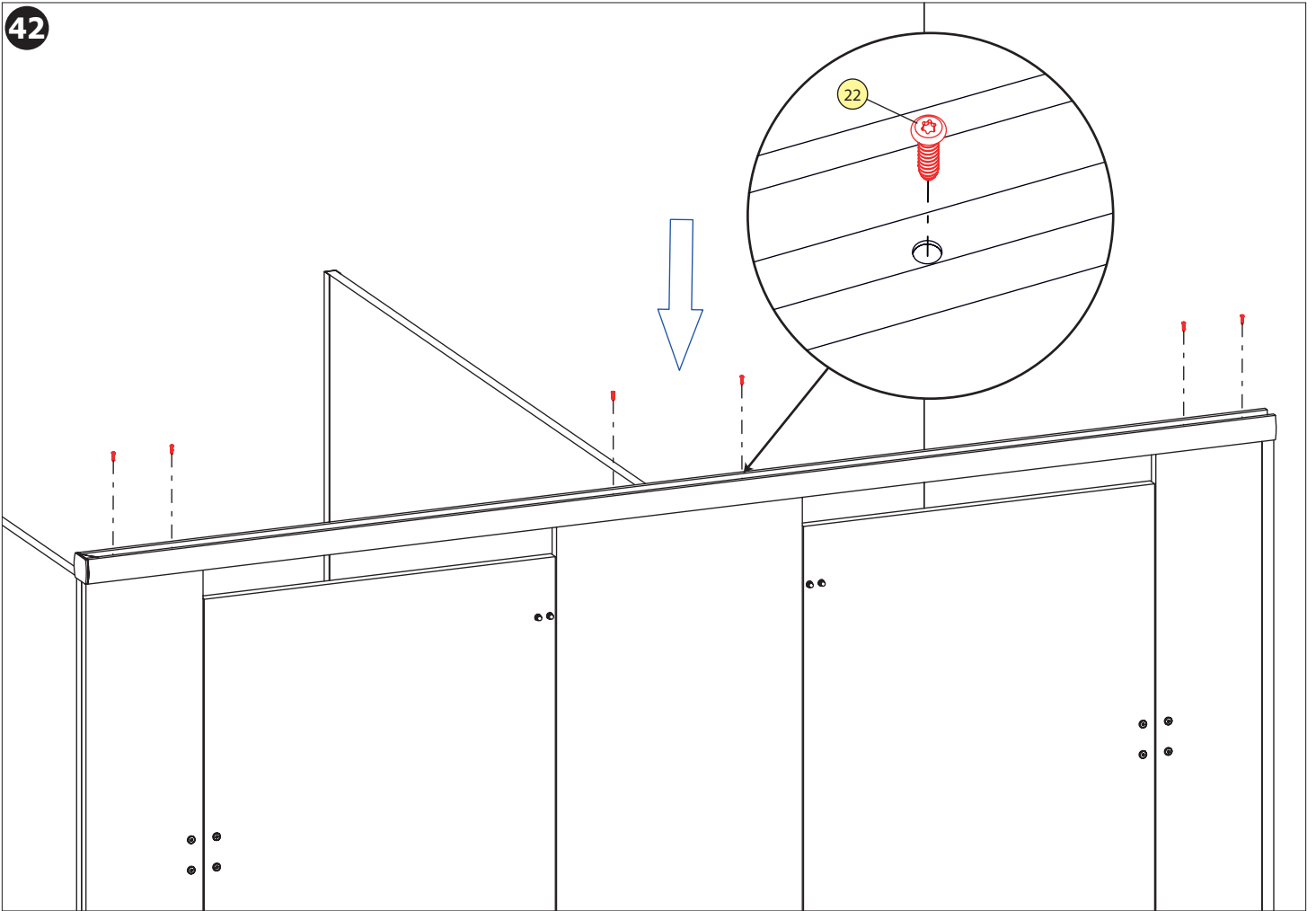

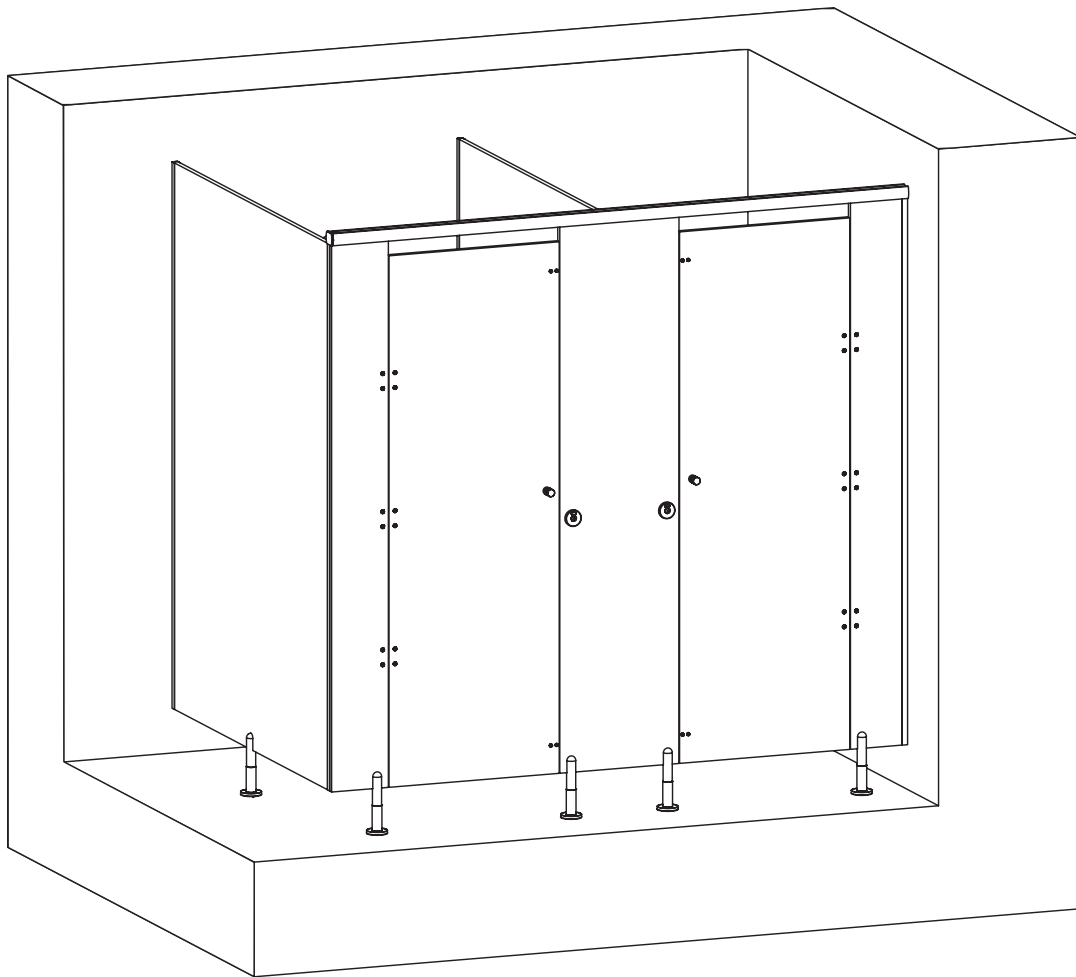

(CS) Návod na údržbu	(RU) Инструкция по уходу	(RO) Instrucțiuni de întreținere	(NL) Onderhoudsinstructies
(SK) Návod na údržbu	(DE) Wartungsanleitung	(ES) Instrucciones de cuidado	(LT) Priežiūros instrukcija
(EN) Instructions for maintenance	(PL) Instrukcja obsługi	(FR) Instructions pour l'entretien	(HU) Karbantartási utasítások

Ke stažení zde
For download



(CS) Návod na skladování	(RU) Инструкция по хранению	(RO) Instrucțiuni de depozitare	(NL) Opslaginstructies
(SK) Návod na skladovanie	(DE) Anweisungen zur Lagerung	(ES) Instrucciones de almacenamiento	(LT) Laikymo instrukcijos
(EN) Storage Instructions	(PL) Instrukcja przechowywania	(FR) Instructions de stockage	(HU) Tárolási útmutató

Ke stažení zde
For download

